

6.5 能带结构的实验研究:

从前面的讨论中已经知道, 通过晶体的能带结构, 特别是对费米面的了解, 就能够理解晶体的各种物理性质, 虽然已经有了许多计算晶体能带和费米面的方法, 但必须得到实验的验证才行。能够证明晶体中出现能带的实验是很多的, 且已经发展了多种测定晶体能带结构的实验方法, 不但有效地验证了能带计算模型和方法的符合程度, 而且也成为探知晶体能带结构, 理解晶体性质的重要手段。

能带实验研究依然要从晶体的热、电、磁及光学性质的测量入手, 经常使用的实验方法有: 电子热容测量; 软 X射线的发射与吸收; 光吸收与磁光吸收; 回旋共振与 **Azbel-Kaner** 共振; 反常趋肤效应; **De Hass-van Alphen** 效应; 磁场电效应 (磁致电阻效应); 超声衰减; 磁声几何效应等

。

我们前面已经提到利用低温电子热容和温度关系可以测定Bloch电子的有效质量 m^* 或 $N(E)$ ，但热容是晶体的整体性质，无方向性，所以给出的只能是各个方向的平均值，对于探知能带结构来说是远不够的。De Hass-van Alphen 效应是测定费米面的有效手段，上节已经比较详细的介绍，这里都不再重复。

- 一. 软 X 射线的发射与吸收
- 二. 光吸收与磁光吸收
- 三. 回旋共振与Azbel-Kaner 共振
- 四. 反常趋肤效应
- 五. 磁声技术
- 六. 角分辨光电子能谱 (ARPES)

参考: Kittel 8版 9.4 节p167
Busch 书 6.8节

一. 软X射线发射谱:

当晶体被一束高能电子轰击时, 低能带的一些电子被激发, 会留下一些空能级, 如果电子从价带或导带落入这些空能级, 就会发射出一个软 X射线范围的光子, 记录下这些光子的能量范围和强度变化即可探知价带或导带电子分布情况。

K: 外层电子落入空的1s态而发射的X射线;

L₁: 外层电子落入2s态所发射的X射线;

L₂: 外层电子落入2p态所发射的X射线。

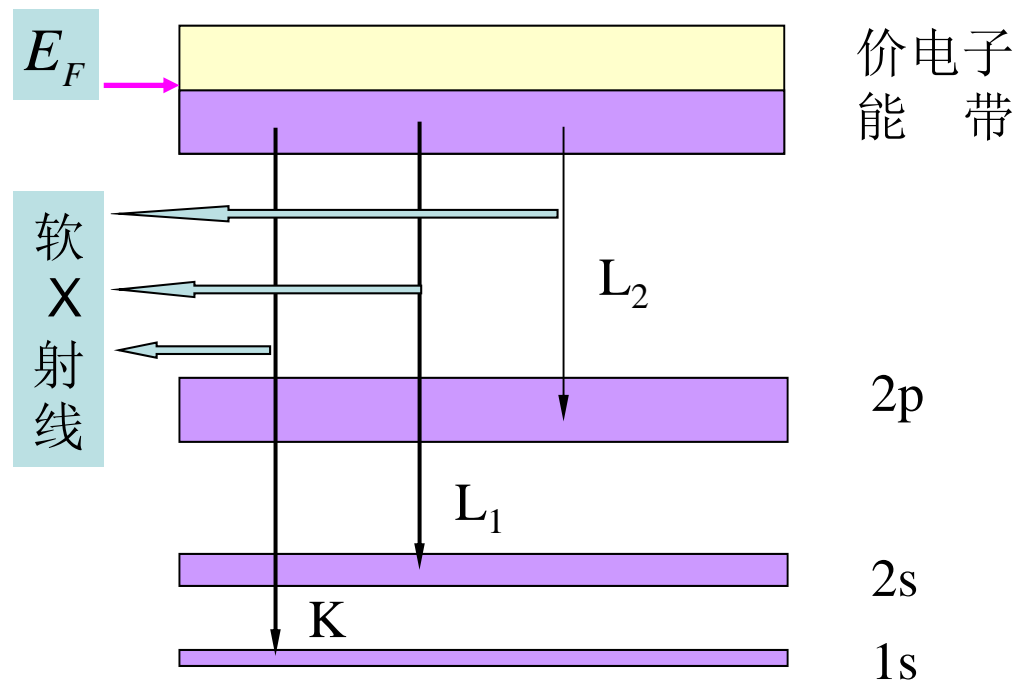

由于低能带和导带或价带相比非常窄，几乎可以看作是分立能级，电子从能级准连续分布的价带上不同能级跃迁到内层将发射不同能量的光子，因而测得的能量范围应该和价带中电子占据的范围（即和费米能级）相当。

又因为发射谱的强度： $I \propto N(E) \times$ 跃迁几率(随能量变化不大)

测得的X射线发射谱强度的变化可以直接地反映出价电子能带能态密度的状况。金属和绝缘体是明显不同的。

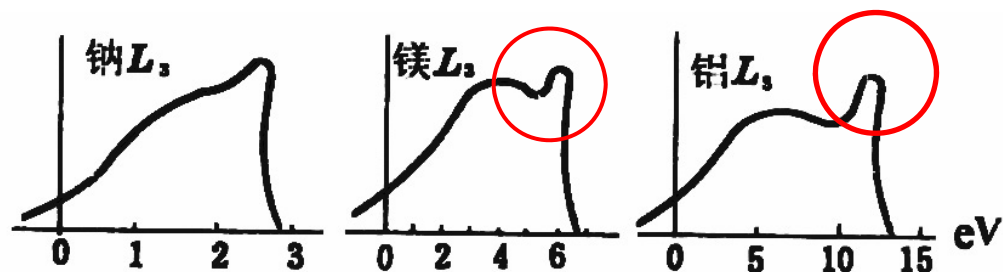

金属的发射谱
高端突然下降

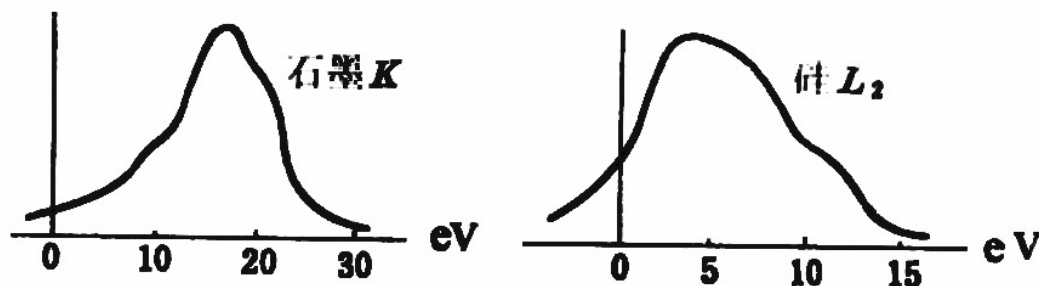

而绝缘体的发射谱
两端都缓慢下降

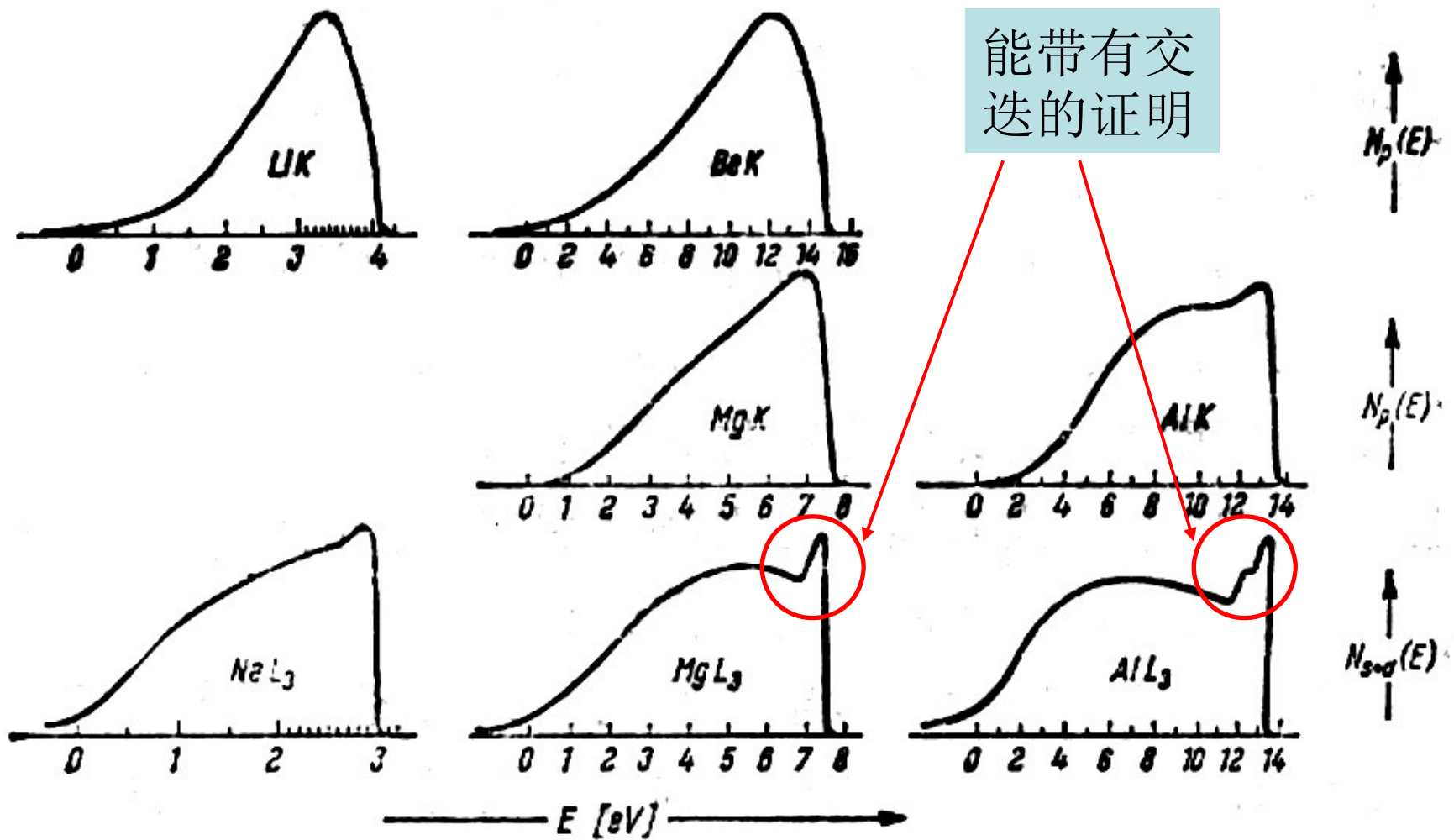

见Busch
书 p251

几种不同金属的X射线发射谱。K和L₃表示能项。电子由导带向这些能项所代表的能级跳跃而发射X射线

金属发射谱的特征是在高能端出现突然的强度降落，发射边和费米能的位置相对应， $E > E_F$ 后，态密度 $N(E)$ 急降至零。在谱的低端，强度的下降相当于 $N(E)$ 逐渐下降至零的情形。强度谱的形状还受多种因素影响，但发射谱的宽度应与费米能值相当。如果与自由电子费米能计算值比照还可估算出 m^* 。

通过软 X 射线发射测量得出的金属费米能（参照上面曲线）

〔按自由电子模型 (5.24) 式计算的和从 X 射线
发射谱实验测定的值〕

$$E_F = \frac{\hbar^2 k_F^2}{2m}$$

元 素	ζ [电子伏]		m / m^*
	理论值	实验值	
Li	4.7	4.2 ± 0.6	0.89
Na	3.2	3.5 ± 1	1.09
Be	13.8	13.5 ± 2.5	0.98
Mg	7.2	4.0 ± 1.5	0.55
Al	12.0	16.0 ± 2	1.33

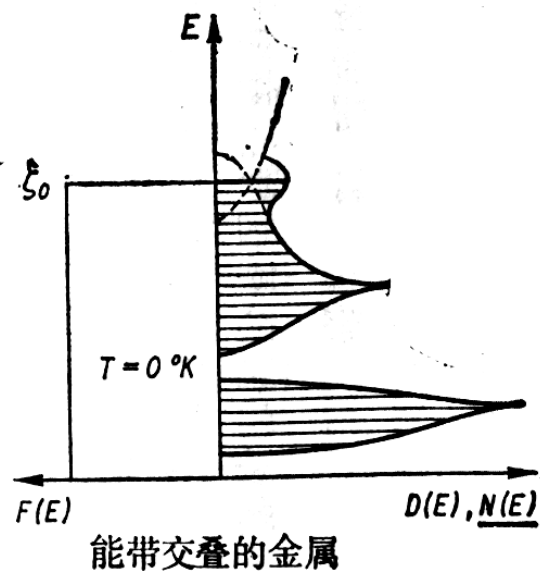
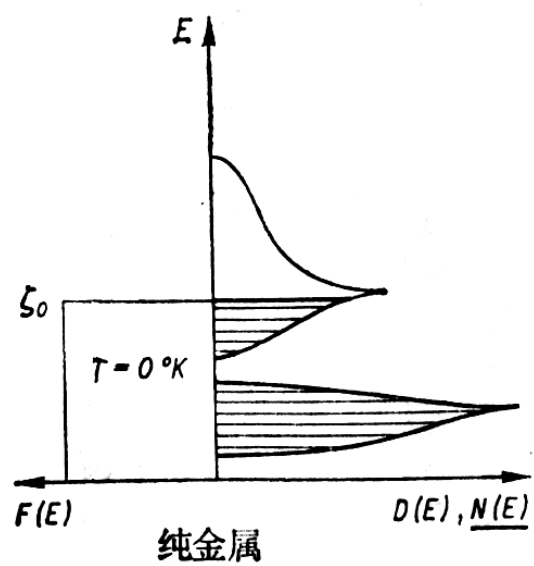
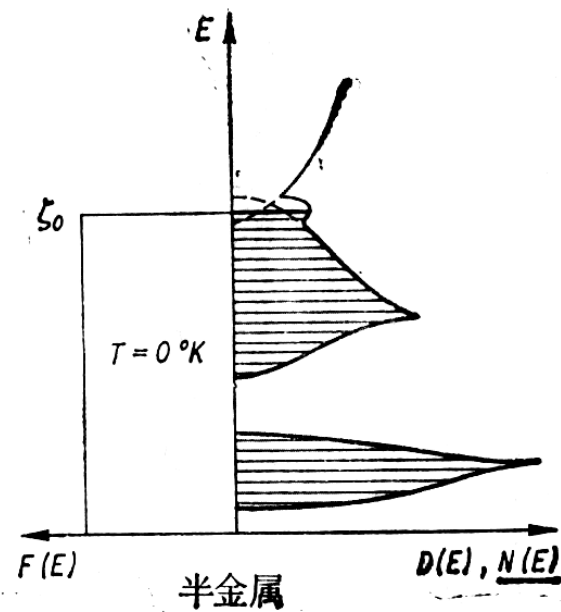
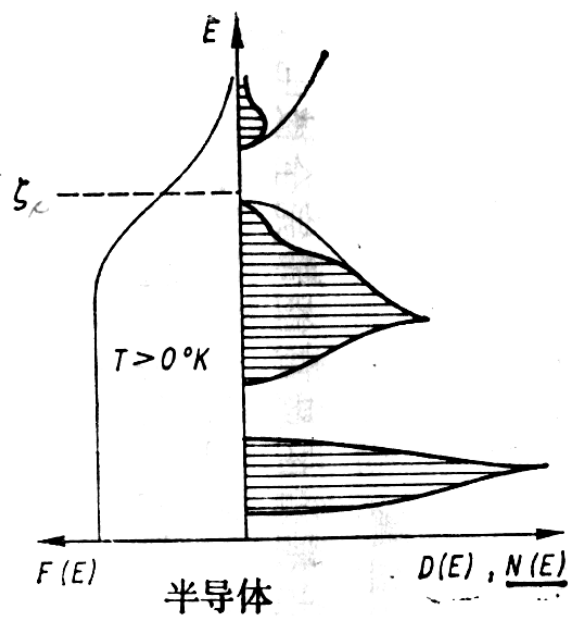
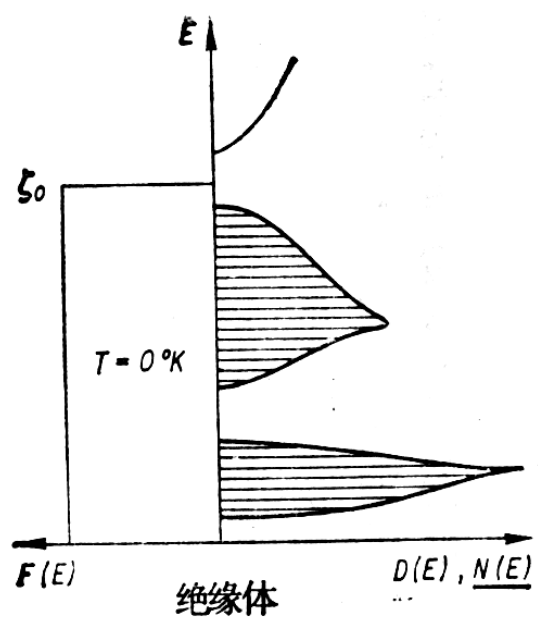

绝缘体、金属、半导体和半金属的分布函数

说明：在前面的的讨论中，我们已经看到求得态密度函数 $N(E)$ 的重要性和困难性，要从理论上求出晶体的 $N(E)$ ，必须先给出晶体的能谱 $E_n(k)$ 表达式，一般说来，这是比较困难的（只有自由电子近似下，才有简明的表达式），即便是得到了，由于 $E_n(k)$ 函数的复杂性也会给求解 $N(E)$ 带来不少数学上的困难，因此，从实验上来测定实际材料态密度函数就变得十分重要，软 X 射线发射谱是最常用的实验之一。

此外，X射线的吸收谱——电子从低能级向未被占据态的激发所致——也常被用来测量未被占据态的能态密度。

二. 光吸收与磁光吸收

紫外光技术测定能带结构原理图如下所示：当光束射到金属上时，电子从费米能级以下跃迁到较高的一个能带，这种带间吸收可以用光学方法来观察，并获得能带形状的信息。

因为结果涉及到两个能带，所以但只能先知道一个能带的形状，才能探知另一个能带情况。大多数金属的吸收频率位于紫外区。

见Omar 书p270



图5·46 带间光吸收。

光学区段的光子能量仅足以激发同一能带中占据态与非占据态之间的跃迁（带内跃迁）或者相邻能带之间的跃迁（价带与导带之间的带间跃迁），在这一能谱区中（ $10^{-5}\text{cm} \sim 10^{-3}\text{cm}$ ），绝缘体和半导体的吸收性质与金属的完全不同，可以直接得出价带与导带间能隙大小的信息，入射波能量只有达到最小的能隙值时，价带的电子才能被激发到导带中去，故绝缘体和半导体的强吸收从 $\hbar\omega_{\min}$ 开始，这个最小能量值由能隙宽度给出： $E_g = \hbar\omega_{\min}$

$\hbar\omega_{\min}$ 对应的波长称作基本吸收的吸收边。实际情况中影响光吸收的因素是复杂的，给出的能带信息需要仔细分析。GaAs 的情况较简单，吸收主要决定于直接跃迁，吸收边很陡，其位置相当于价带和导带之间的能差，见下页图。

给出禁带宽度

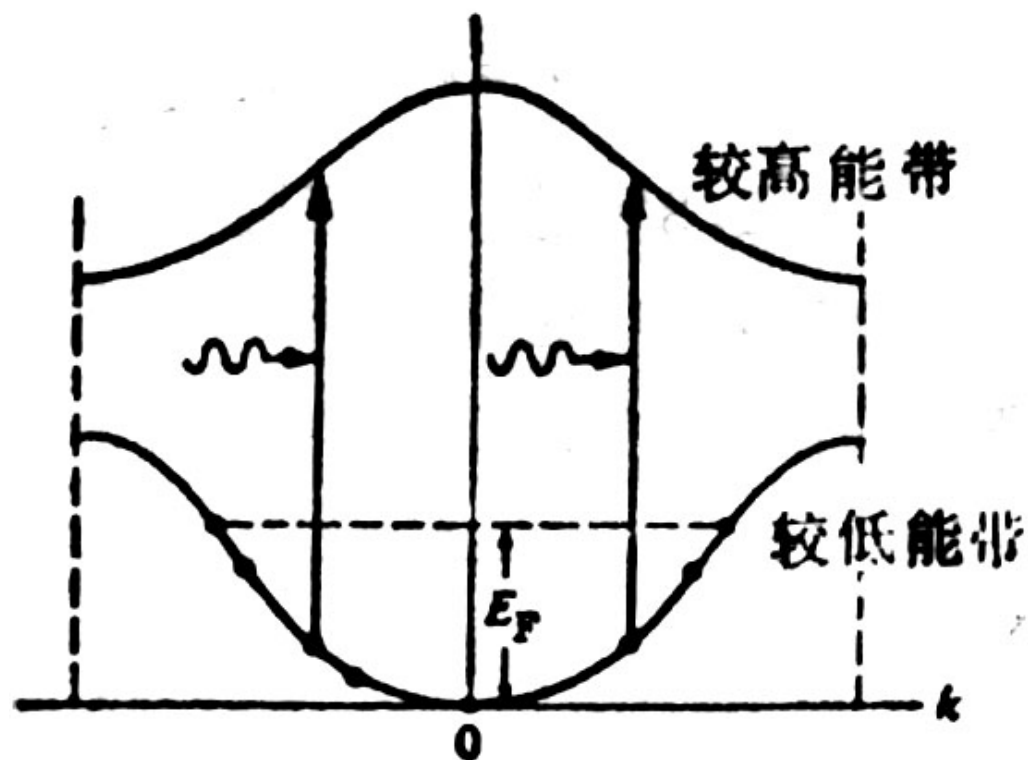
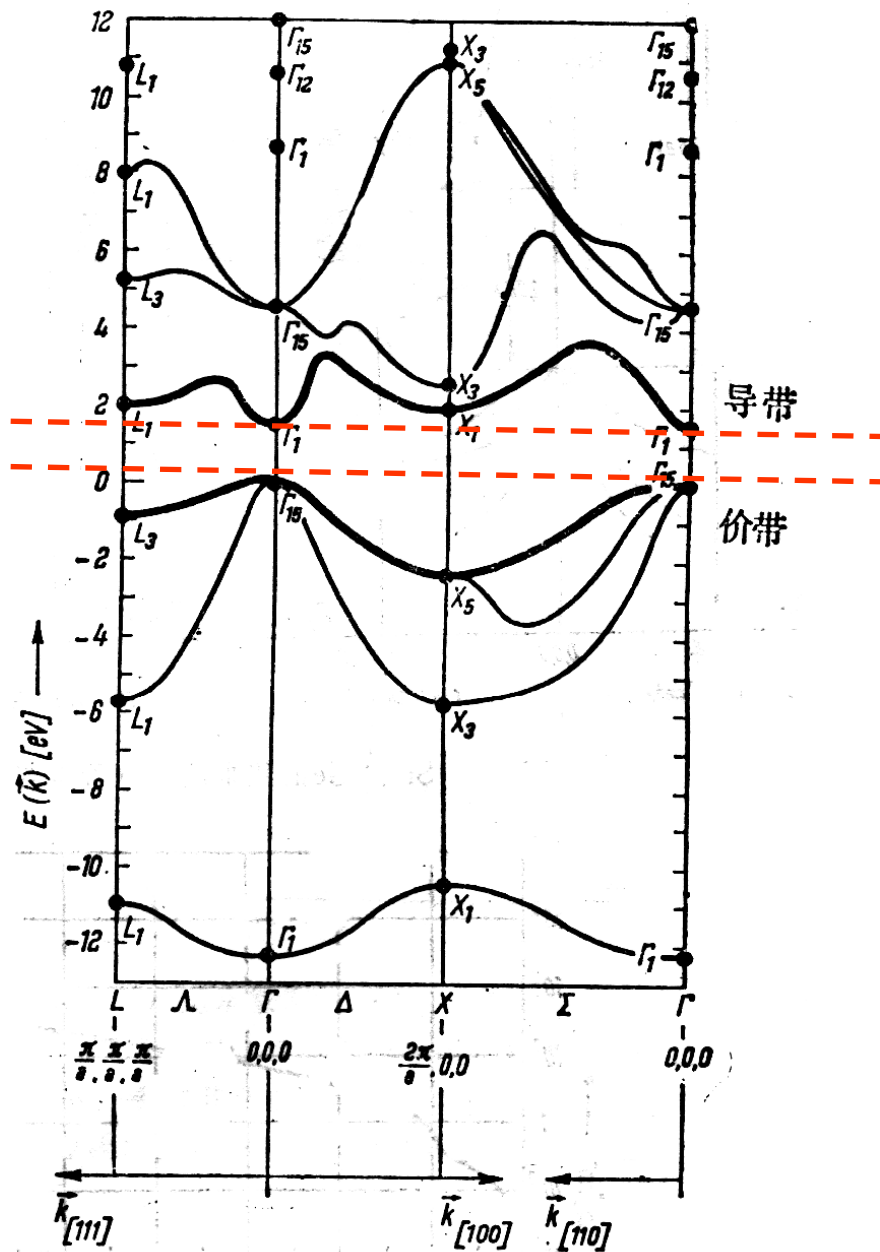

GaAs的能带结构。字母 L, Δ, Γ 是群论中的符号，系指布里渊区中的对称线和对称点

三. 回旋共振与Azbel-Kaner 共振

前面已经提到利用回旋共振能够测定有效质量的张量分量，因而能够确定相应能量曲面的曲率，这样我们就可以得知费米面的形状或者得知对应于价带顶或导电底等能面的情况。在回旋共振的测量中除去必须满足 $\omega_c \tau > 1$ 外，还必须考虑到交变电场穿入样品的程度，计算表明只有载流子数目较少的半导体样品，这个条件才容易满足。Si、Ge的回旋共振有明显的方向性，说明相应的能量曲面不是球形。通过仔细分析给出了它们导电电子的能量曲面形状。

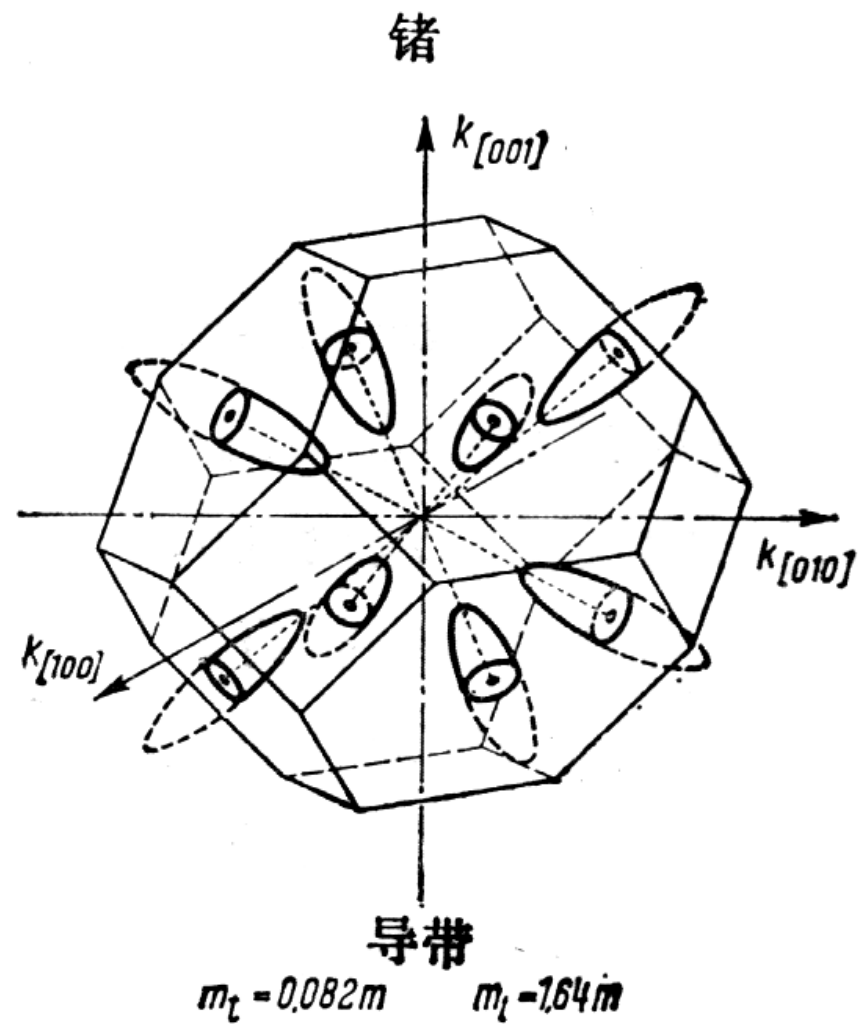
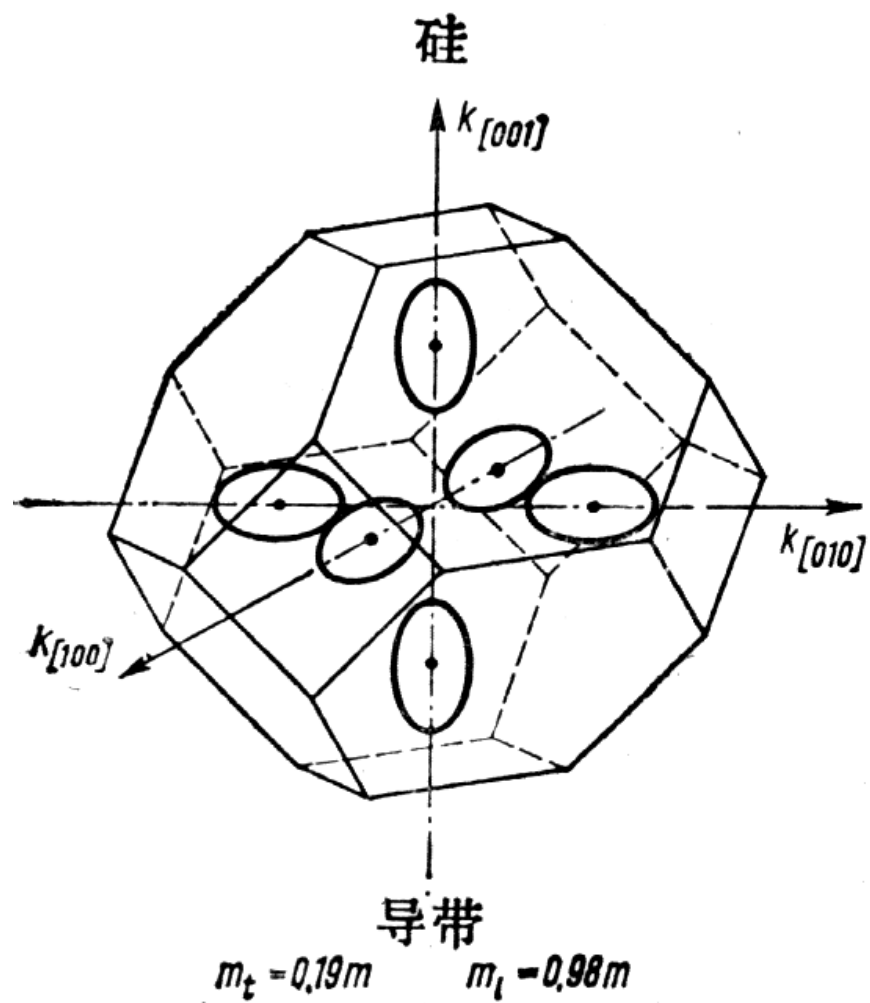

Si与Ge中导电电子的能量曲面

经典回旋共振的安排下，金属电阻率低，射频信号不能透入样品太深，致使共振现象难以观察，

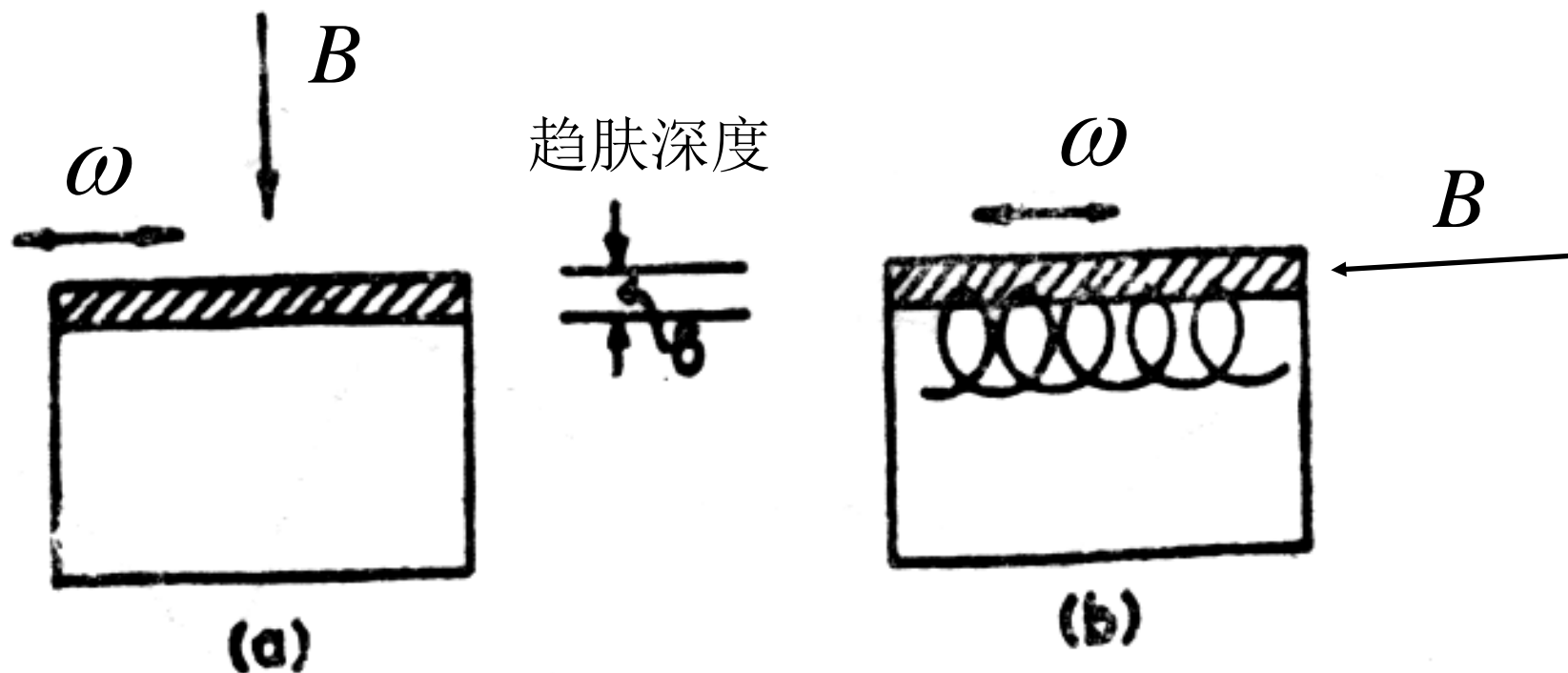

回旋共振的几何方案略图：

(a) 经典的；(b) Azbel'-Kaner的

一种可以用于测量金属回旋共振的方法称作 Azbel-Kaner 共振，沿着金属表面加上磁场和交变电场，电子以周期 ω_c 做回旋运动，频率为 ω 的顺时针方向圆偏振交变电磁场沿金属表面传播，只能穿透很小的范围，其值等于趋肤深度，但电子的回旋运动是超过这个深度的，因此共振条件变为： $\omega = l\omega_c$

这里 $l = 1, 2, 3, \dots$

实际测量中是维持 ω 不变，而改变磁场强度以满足上式。

测得Cu的AKCR谱见下图。

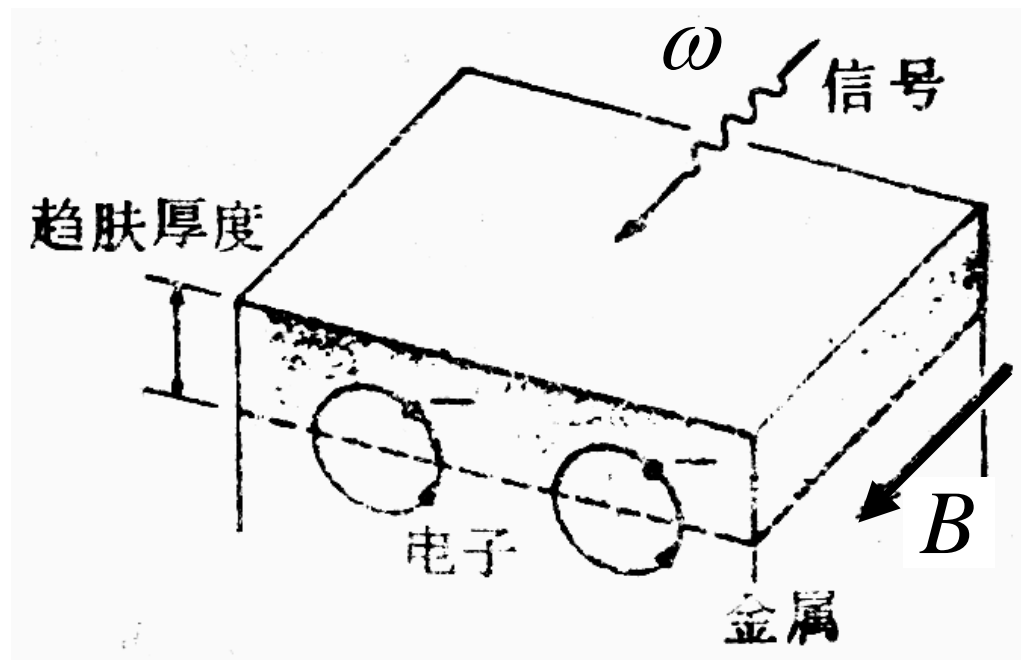

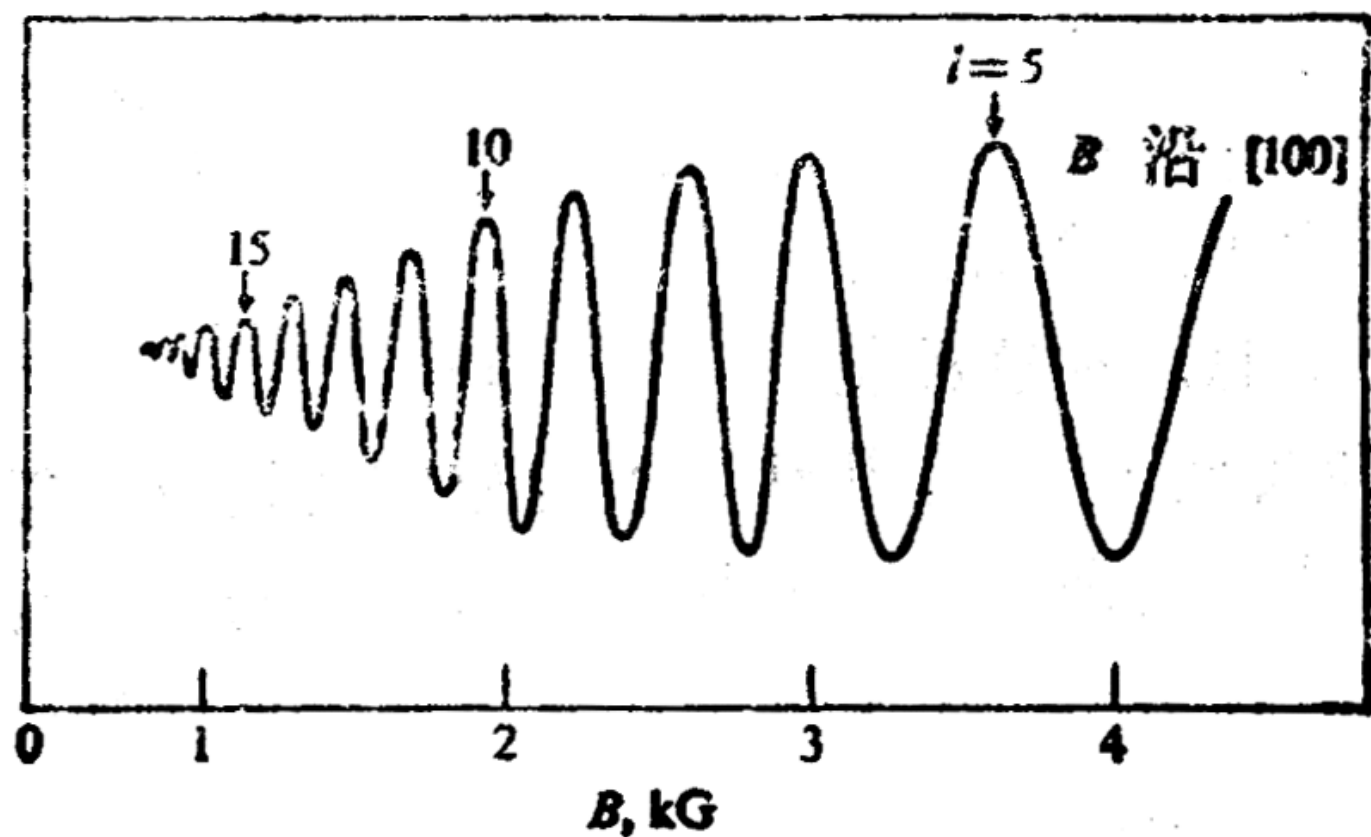

$T = 4.2 \text{ K}$ 时 Cu 的 AKCR 谱。晶体表面（上表面）沿 (100) 面切割，曲线的纵坐标表示表面电阻率对磁场的导数。[引自 Haüssler and Wells, Phys. Rev. 152, 675, 1966]

这种方法不仅可以用来测出 ω_c , 从而算出有效质量 m^* , 还可以用来确定费米面的形状, 因为电子在费米面的不同区域具有不同的回旋频率, 最强的效应发生在与磁场垂直的FS的极值截面——即最大和最小截面。因此改变磁场取向, 测得各个方向的极值截面即可绘出费米面的形状。

和普通回旋共振一样, 也需要低温强磁场和高纯样品, 以保证满足 $\omega_c \tau \gg 1$ 的条件, 在这种极限条件下, 电子在一次碰撞时间内, 完成了多次回旋, 可以得到一个尖锐的具有高分辨率的共振。

四. 反常趋肤效应: (见Busch 书p258)

五. 磁声技术和其它:

利用晶格振动和布里渊区、乃至和费米面的关系发展起来磁声技术，尤其是几何共振已经成为测量费米面大小的重要方法，它的最大特点是能够测量在 k 空间任何方向的 k_F 数值，这是其它方法很难做到的。

正电子湮灭技术也是研究金属及合金费米面的有力工具。更扩展一些说：**凡是已经确切知道和费米面关系的物理性质，都可以用来测量费米面的性质。**

六. 角分辨光电子能谱 (ARPES)

Why ARPES?

Angle-Resolved Photoemission Spectroscopy

CRYSTAL STRUCTURE

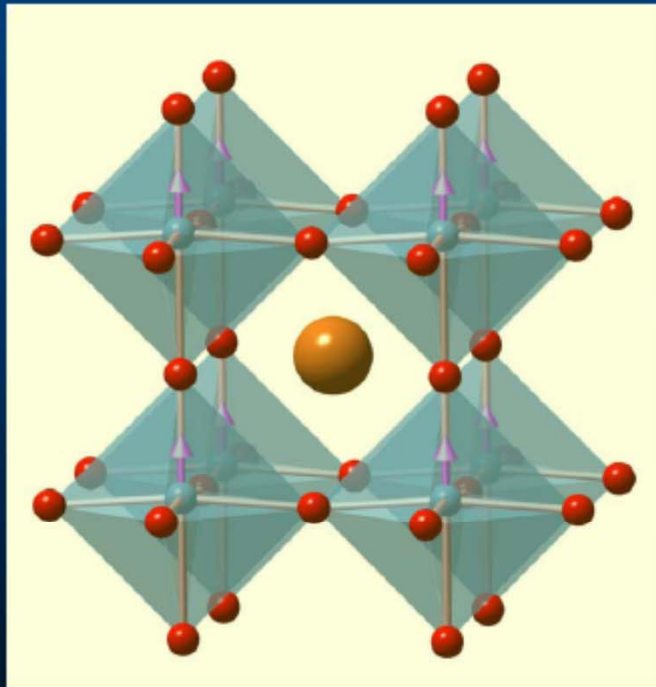

ELECTRONIC STRUCTURE

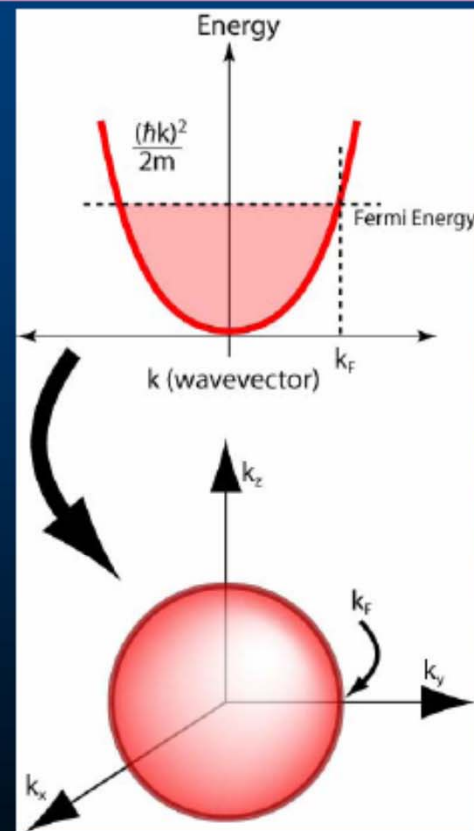

X-ray diffraction



Photoemission

History of Photoemission

The Photoelectric Effect

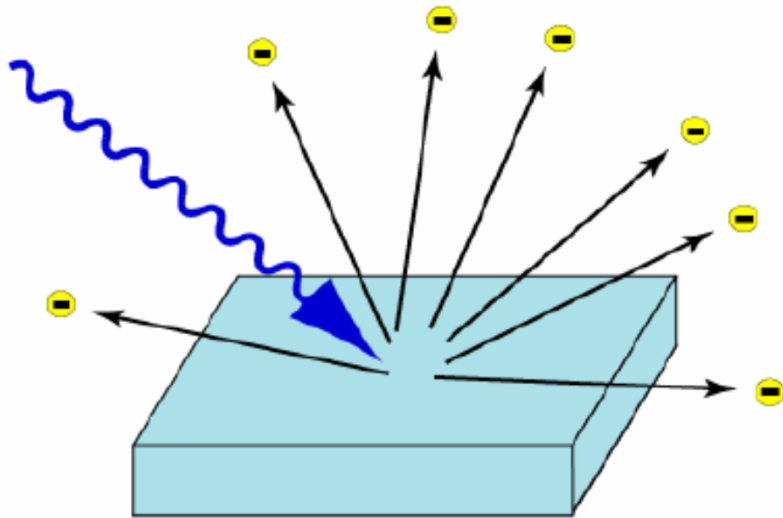

- First experimental work performed by H. Hertz (1886), W. Hallwachs (1888), von Lenard (1900)
- Theoretical explanation by Einstein (1905)

**FIRST EXPERIMENTAL EVIDENCE
FOR QUANTIZATION OF LIGHT!**

Is there anything else we can learn from the photoelectric effect?

Insights into the solid-state!

Understanding the Solid State: Electrons in Reciprocal Space

Many **properties** of a solids are determined by **electrons near E_F** (**conductivity, magnetoresistance, superconductivity, magnetism**)

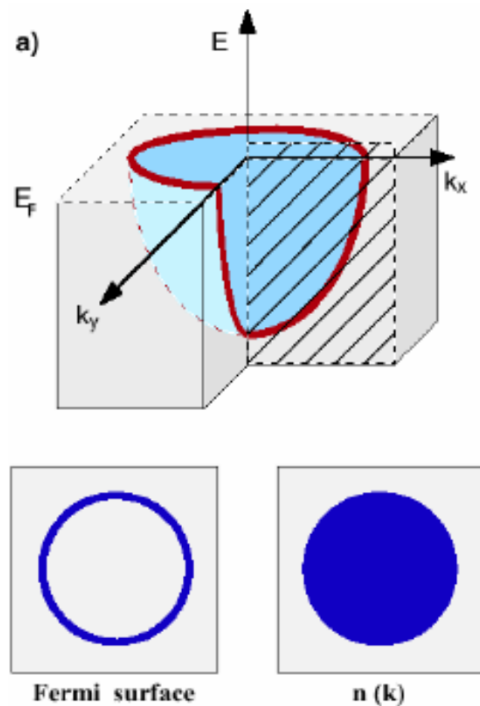

Only a **narrow energy slice** around E_F is relevant for these properties (**$kT=25$ meV** at room temperature)

Allowed electronic states
Repeated-zone scheme

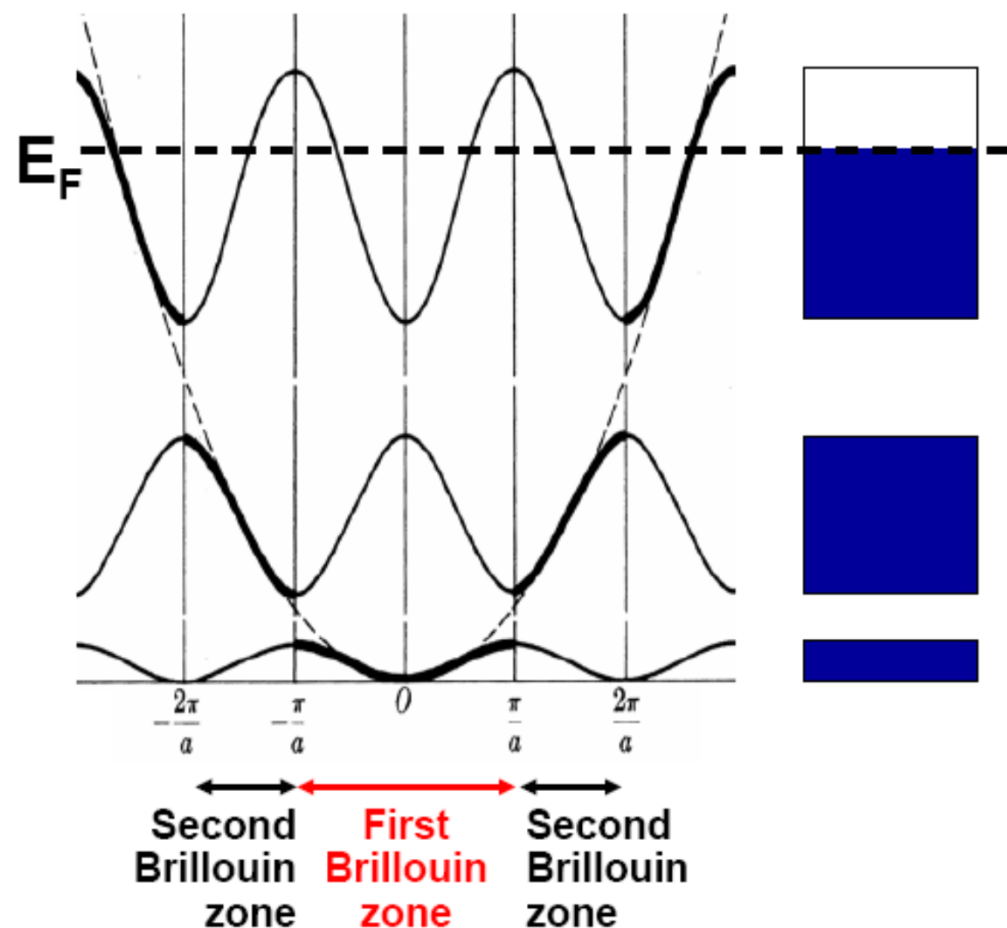

Angle-Resolved Photoemission Spectroscopy

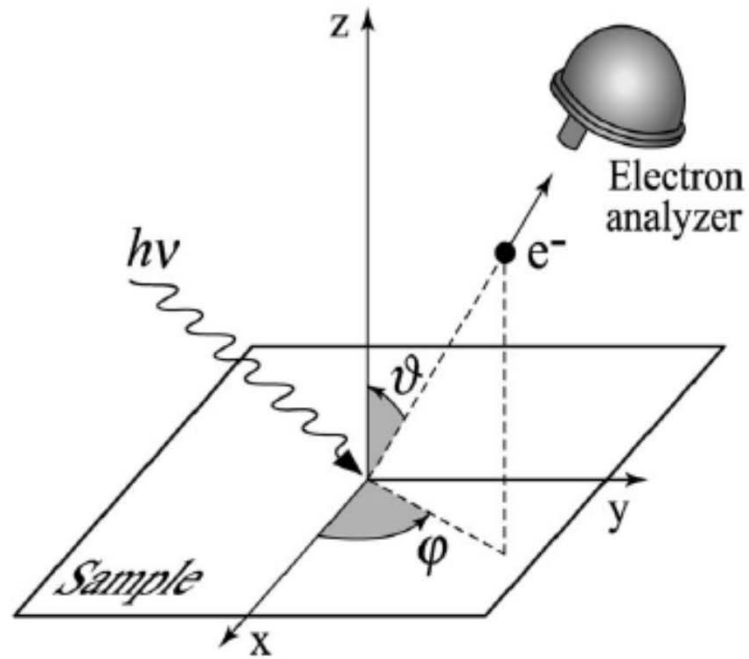

Photoemission geometry

Measured Quantities

$$E_{\text{kin}}, \theta, \phi$$

Desired Quantities

$$E_{\text{B}}, k_{\parallel}$$

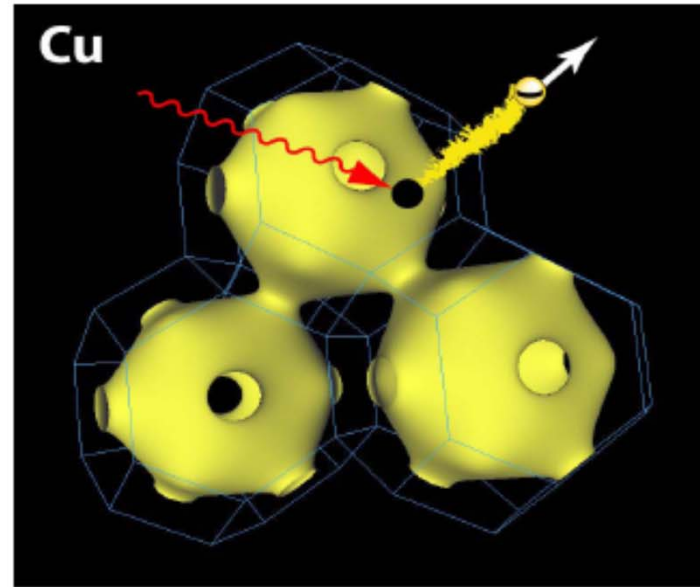

Energy Conservation

$$E_{\text{B}} = h\nu - E_{\text{kin}} - \Phi$$

Momentum Conservation

$$K_{\parallel} = k_{\parallel} + G_{\parallel}$$

$$E_i = h\nu - E_{kin} - \phi$$

$$\mathbf{k}_i = \mathbf{k}_f + \mathbf{G}$$

$$|\mathbf{k}_f| = \frac{(2m_e E_{kin})^{1/2}}{\hbar} \sin \theta$$

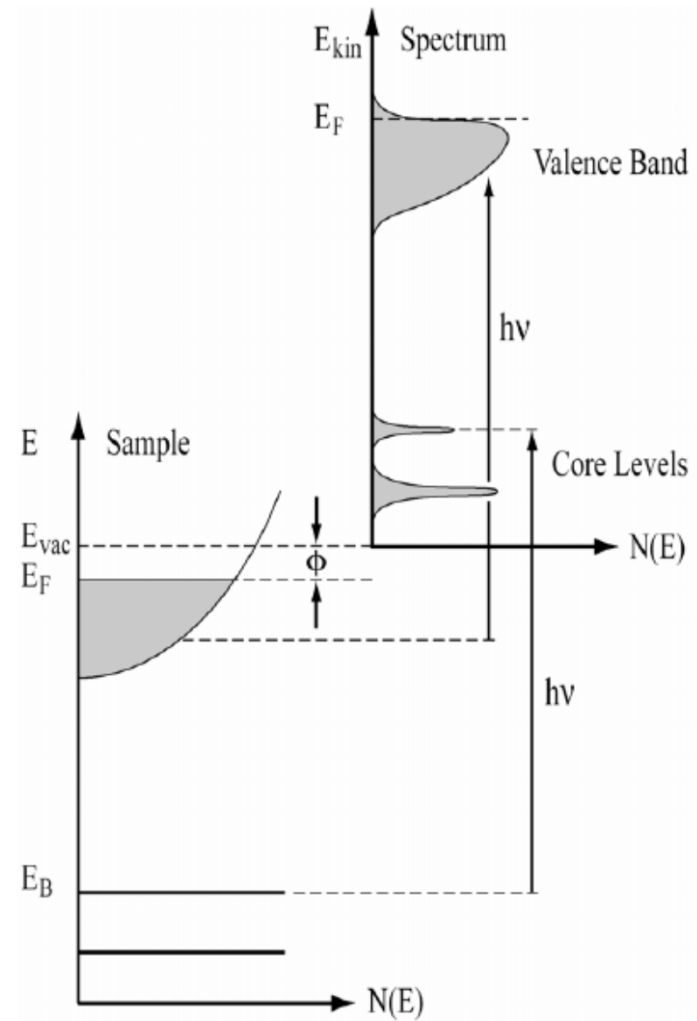

Sensor, in blue displays the intensity of detected electrons, $N(E)$, that have various kinetic energies, E_{Kin} .

These values obtained by the ARPES sensor correspond to the actual values of the "Sample", displayed red. In a solid material, the electrons are distributed to an energy level below E_{Fermi} , the Fermi Level.

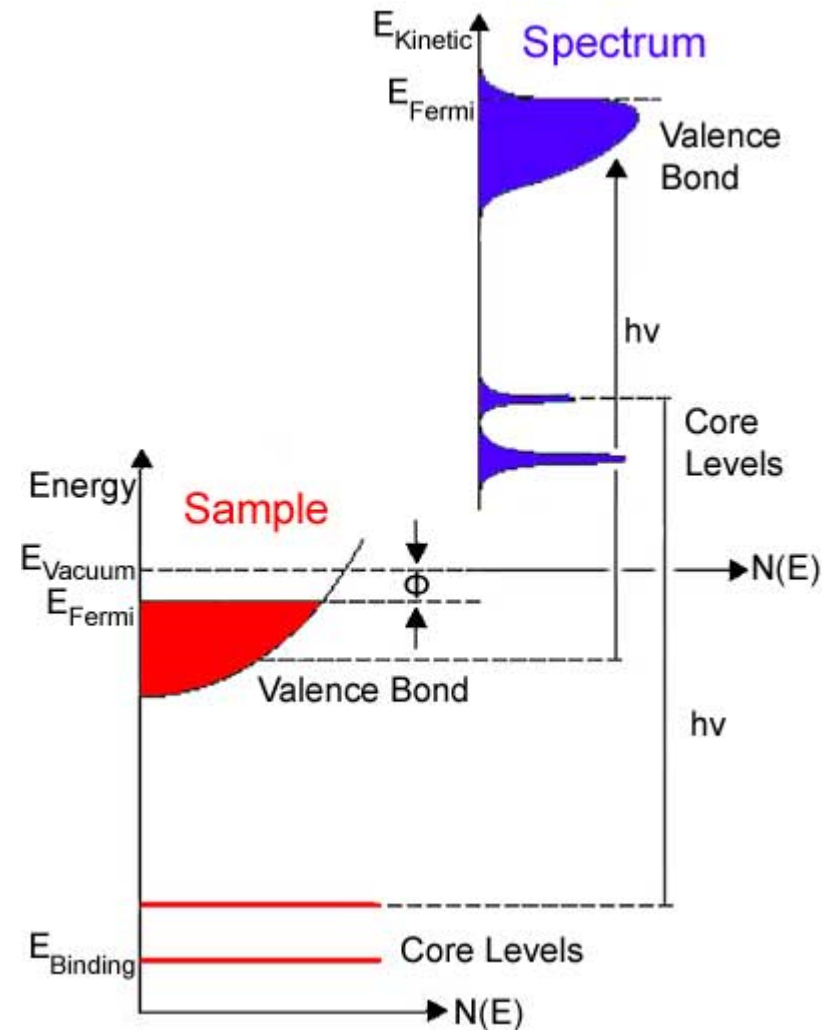

❖ An ARPES sensor collects the photoelectrons, provide information about the photoelectron energy, applying conservation laws of energy and momentum, where the energy and the momentum is conserved before and after the photoelectric effect.

$$E_{K i n} = h \nu - \phi - E_B$$

The crystal- momentum inside the solid

$$p_{||} = \hbar k_{||} = \sqrt{2 m E_{K i n}} \sin \theta$$

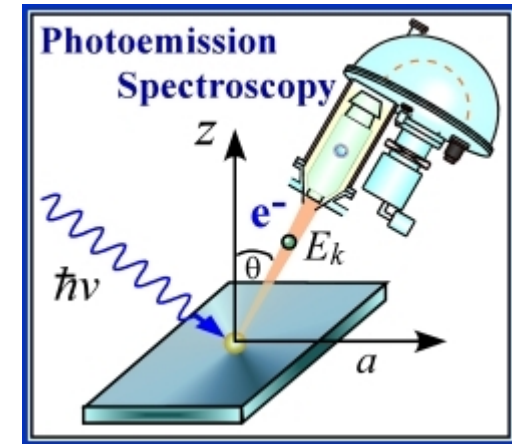

A Simple Example : Cu (111) Surface State

Copper

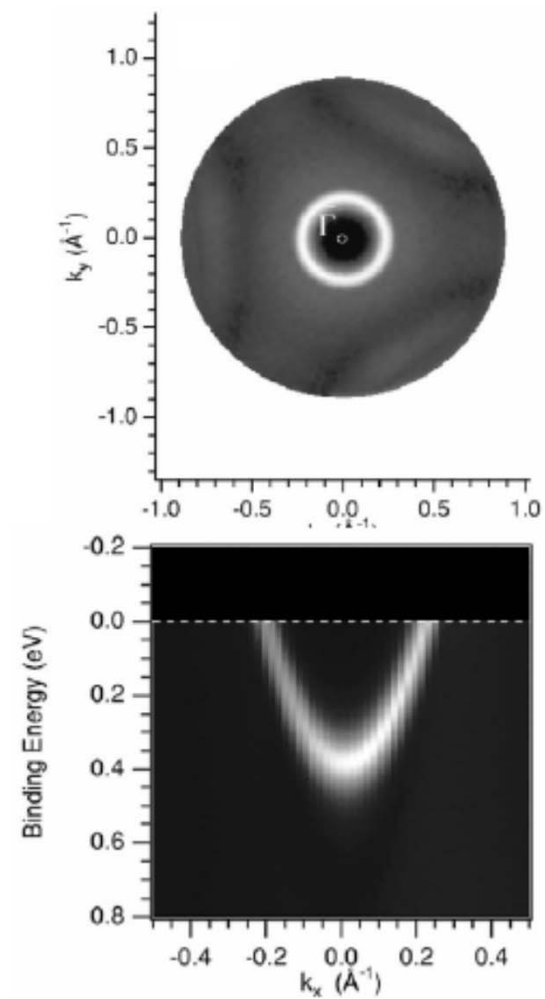
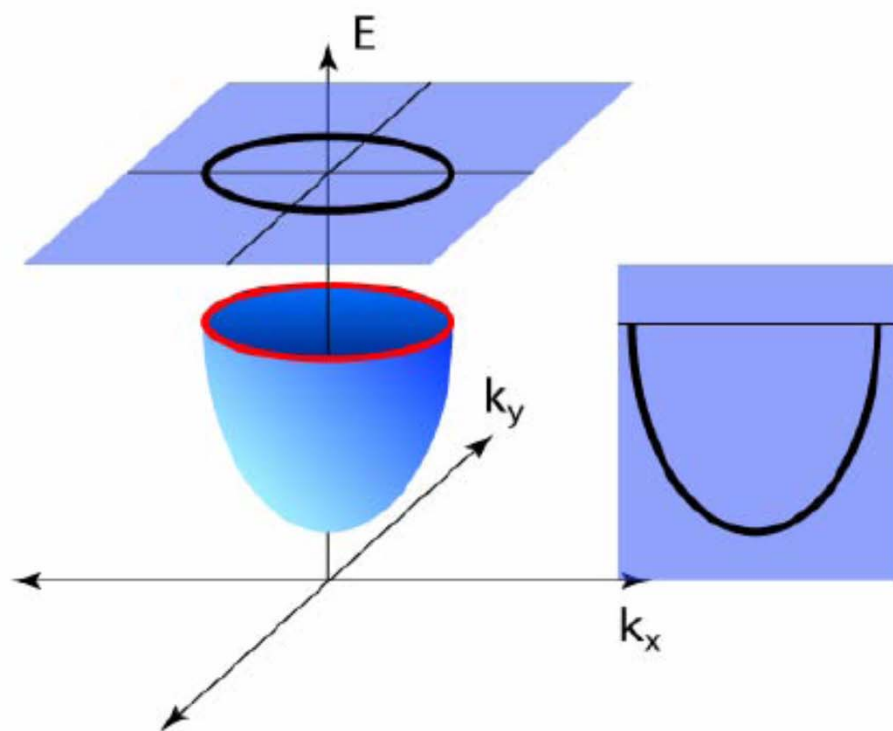

F. Baumberger et al., PRB 64, 195411 (2001)



ARPES : Then and Now

Improvement in Energy Resolution

Ag(111) L-Gap Surface State by PES

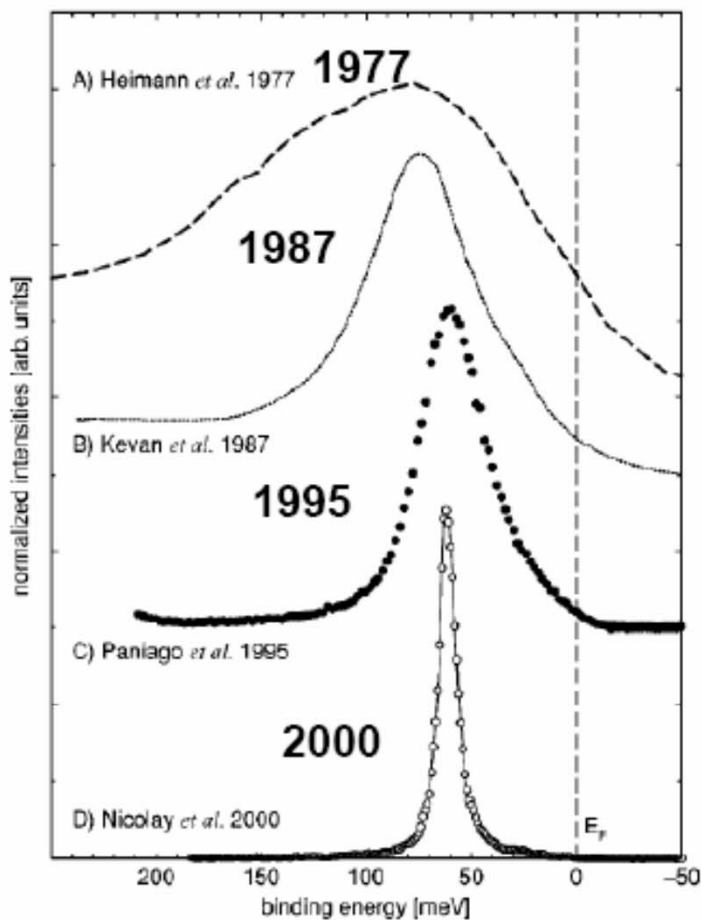

F. Reinert *et al.*, PRB 63 (2001)

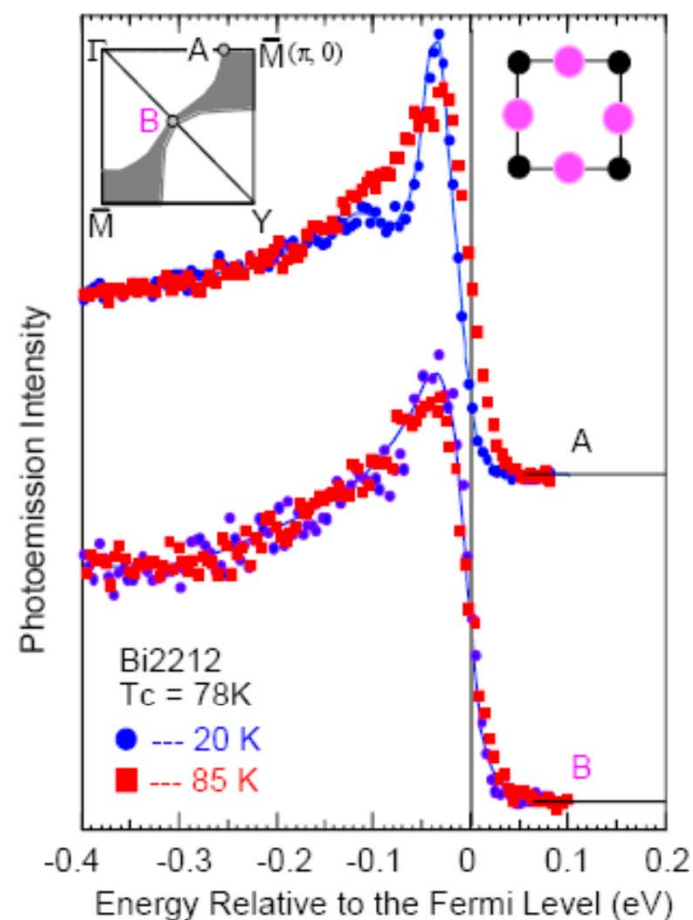

Shen *et al.*, PRL 70, 1553 (1993)

ARPES : Then and Now

Momentum Resolution

High- T_c Cuprates : 1993

High- T_c Cuprates : 2000

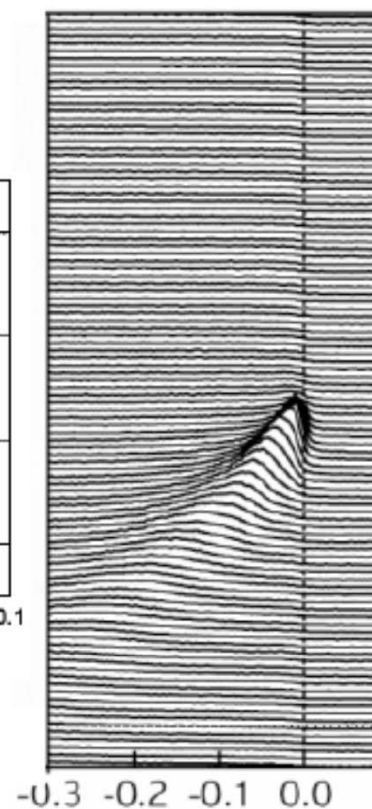
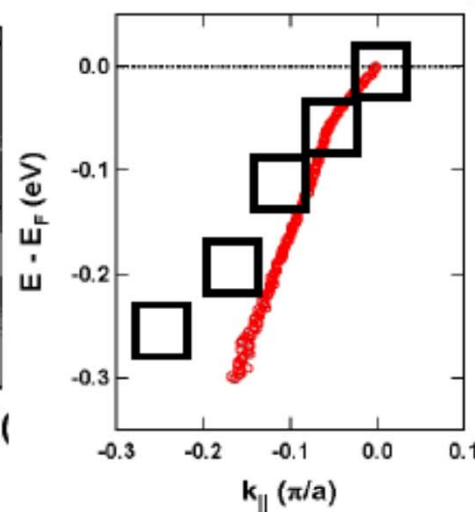
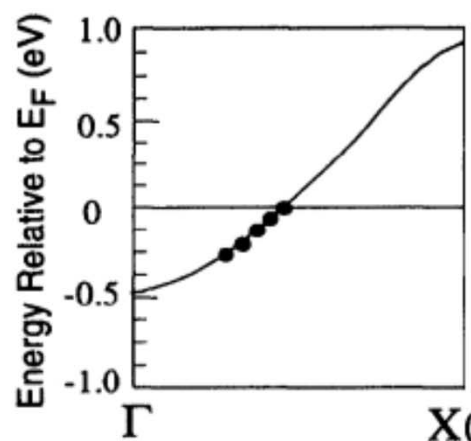
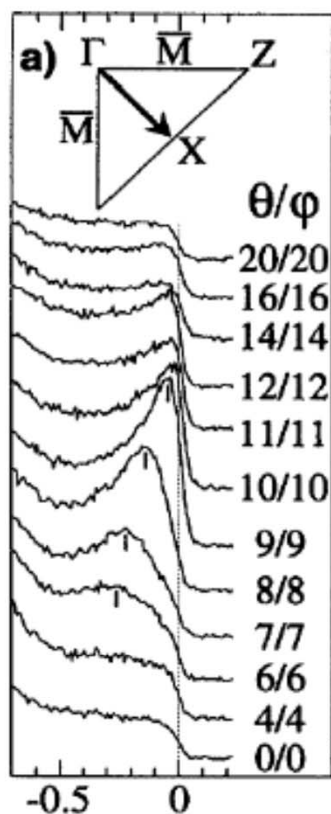

D.S. Dessau *et al.*, Phys. Rev. Lett. (1993)

P.V. Bogdanov *et al.*, Phys. Rev. Lett. (2000)

Angle-Resolved Photoemission Spectroscopy

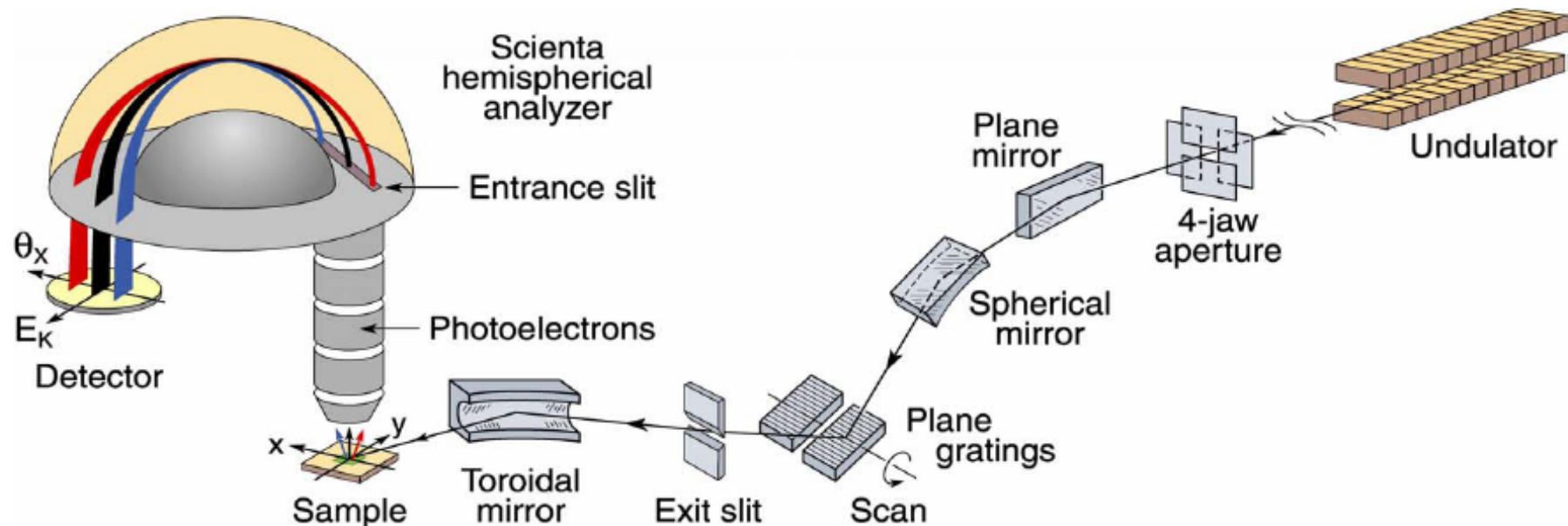

Parallel multi-angle recording

- Improved energy resolution
- Improved momentum resolution
- Improved data-acquisition efficiency

	ΔE (meV)	$\Delta\theta$
past	20-40	2°
now	2-10	0.2°

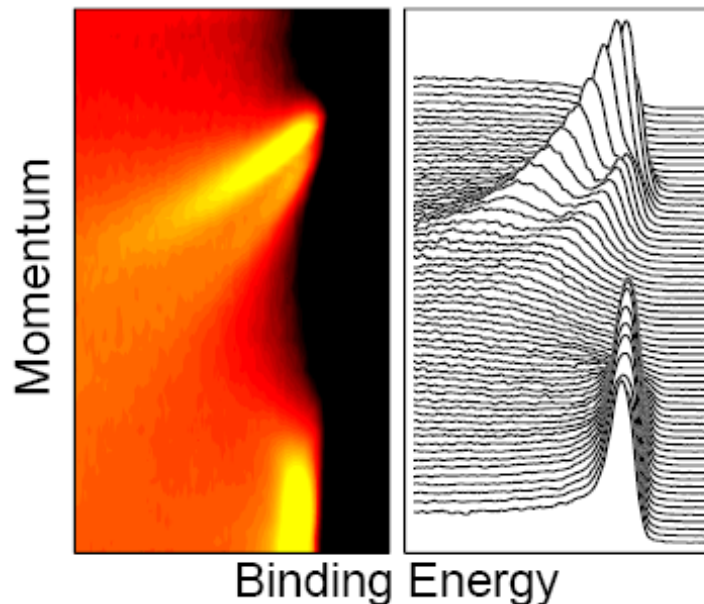

Interaction Effects between Electrons : “Many-body Physics”

Many-body effects are due to the interactions between the **electrons** and **each other**, or with other **excitations inside the crystal** :

- 1) A “many-body” problem : intrinsically hard to calculate and understand
- 2) Responsible for many surprising phenomena :

Superconductivity, Magnetism, Density Waves,

Non-Interacting

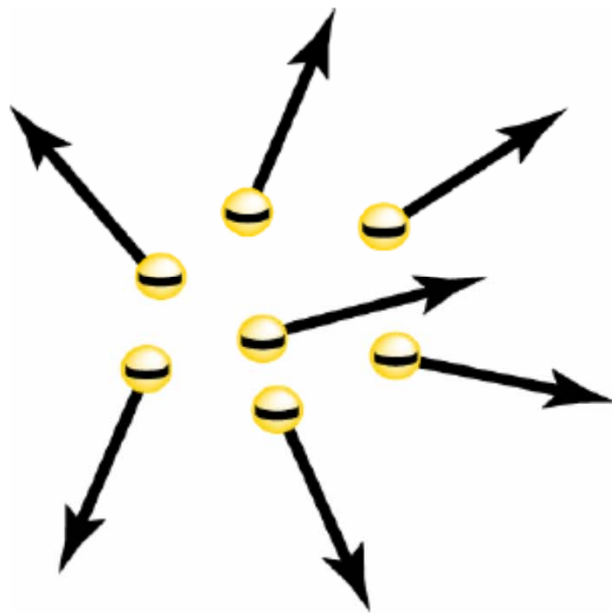

Interacting

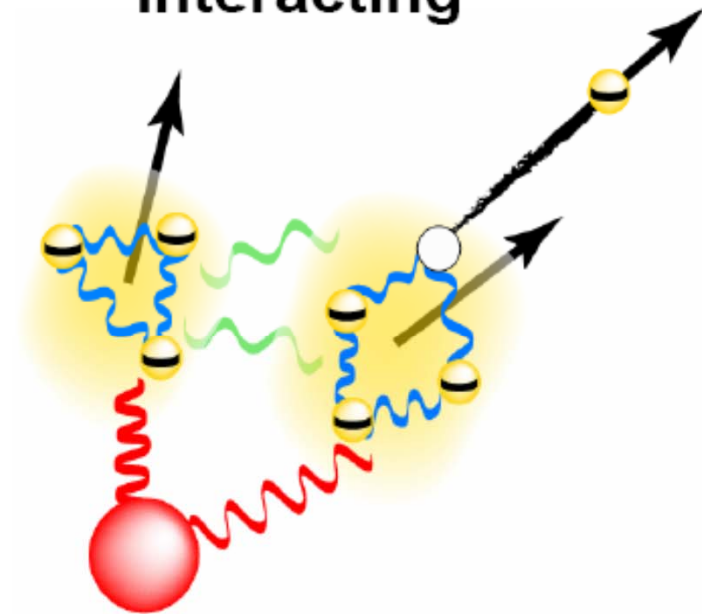

ARPES : A Probe of Interactions

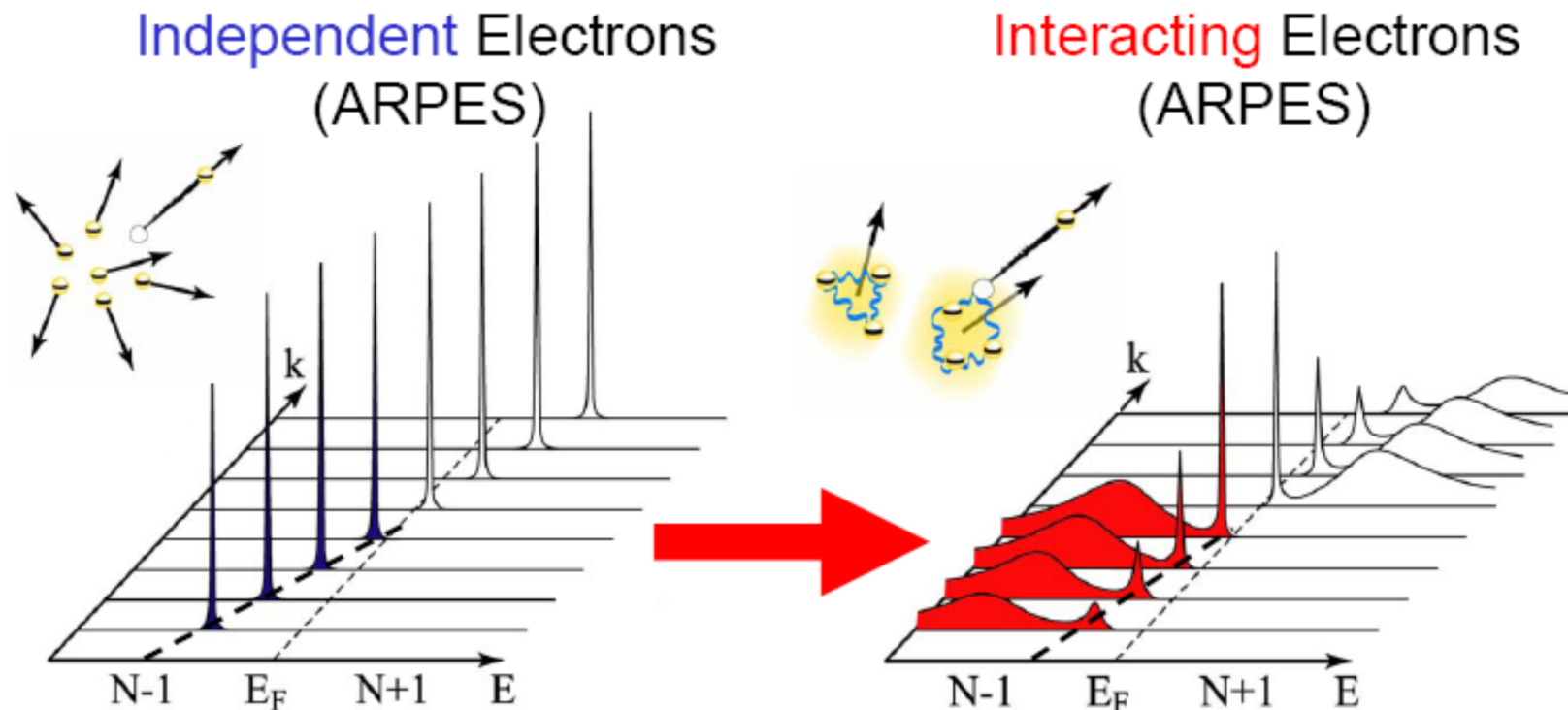

Photoemission intensity : $I(k, \omega) = I_0 |M(k, \omega)|^2 f(\omega) A(k, \omega)$

Single-particle spectral function

$$A(\mathbf{k}, \omega) \propto \frac{\text{Im}\Sigma(\mathbf{k}, \omega)}{[\omega - \varepsilon_{\mathbf{k}} - \text{Re}\Sigma(\mathbf{k}, \omega)]^2 + [\text{Im}\Sigma(\mathbf{k}, \omega)]^2}$$

$\Sigma(\mathbf{k}, \omega)$: *Self-Energy* - Captures the effects of interactions

Fermi Liquid Theory

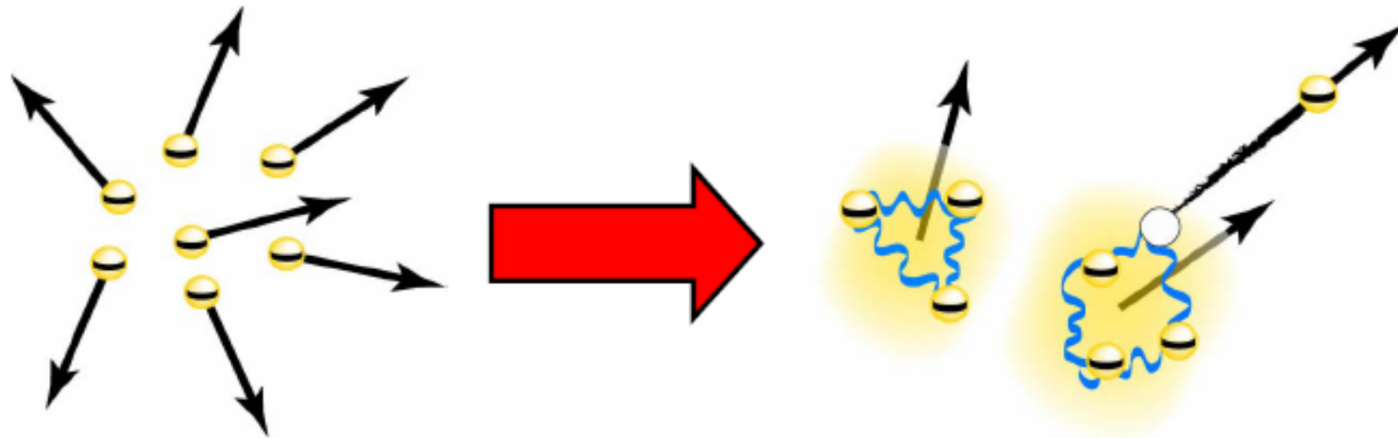

Independent Electrons



Interacting Electrons
“Quasi-particle”

Fermi Liquid Theory

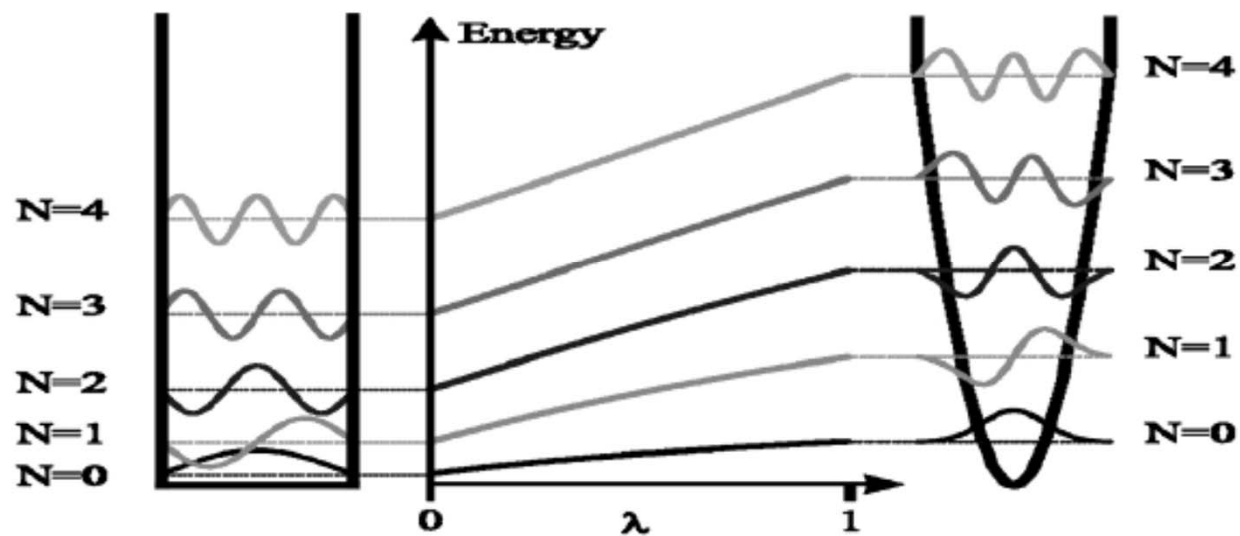
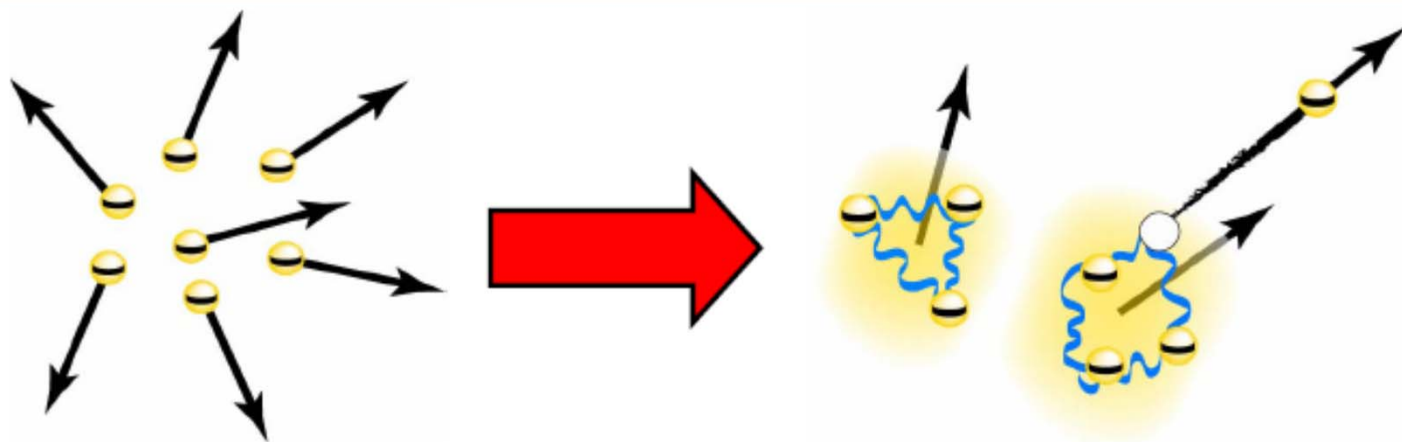

Fermi Surface of Sr_2RuO_4

Fermi Surface from ARPES

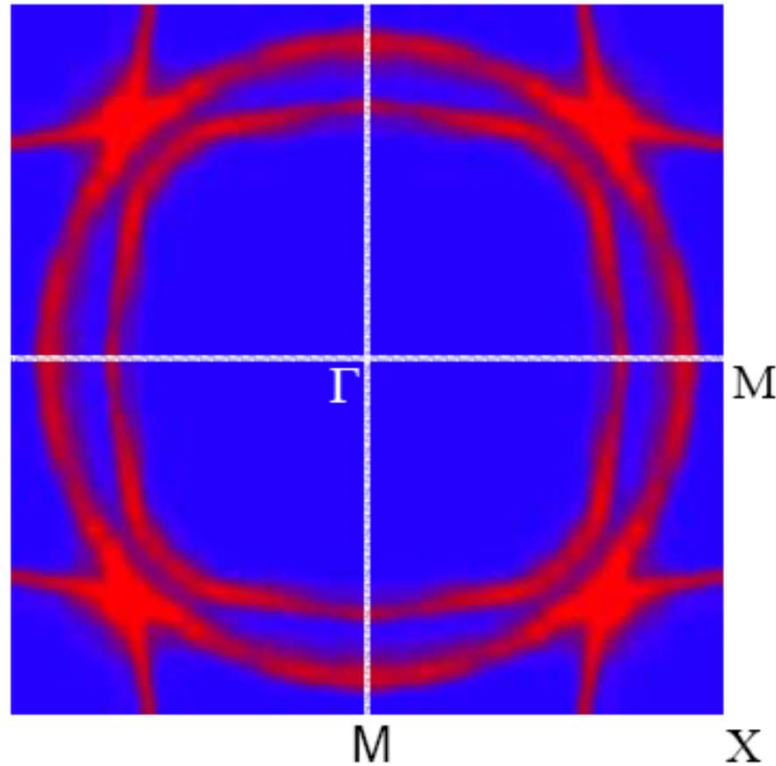

Quasiparticles in Sr_2RuO_4

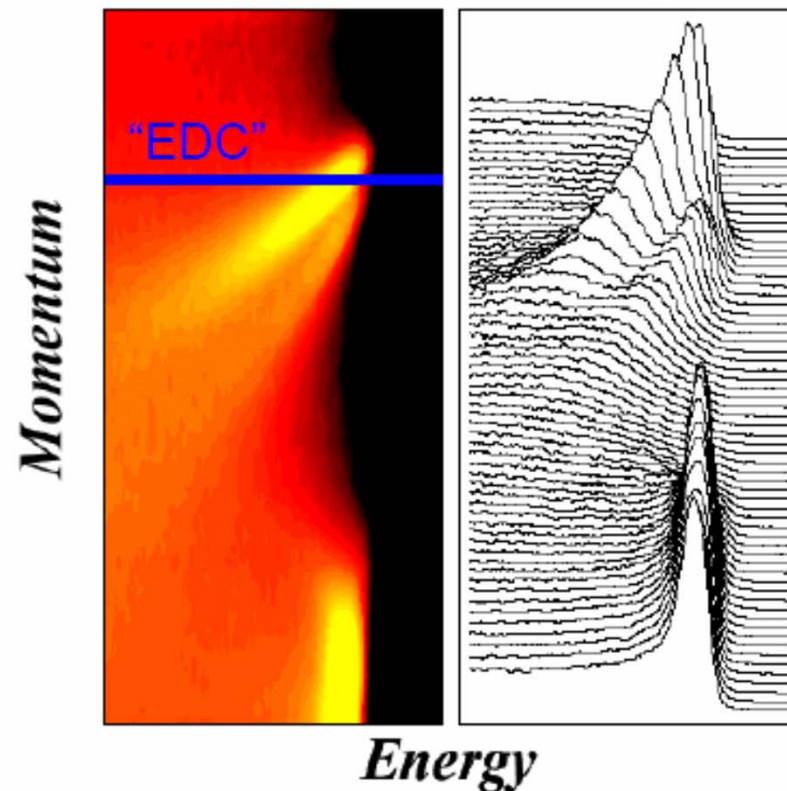

- Luttinger volume obeyed to within experimental error (4.02 electrons in 3 bands)
- Excellent quantitative agreement with both band structure and de Haas-van Alphen

K.M. Shen, A. Damascelli, *et al.* (PRB '01)

A. Damascelli, D.H. Lu, K.M. Shen, *et al.* (PRL '00)

Summary

Exotic Bulk Solids

H																	He	
Li	Be											B	C	N	O	F	Ne	
Na	Mg											Al	Si	P	S	Cl	Ar	
K	Ca	Sc	Ti	V	Cr	Mn	Fe	Co	Ni	Cu	Zn	Ga	Ge	As	Se	Br	Kr	
Rb	Sr	Y	Zr	Nb	Mo	Tc	Ru	Rh	Pd	Ag	Cd	In	Sn	Sb	Te	I	Xe	
Cs	Ba	La	Hf	Ta	W	Re	Os	Ir	Pt	Au	Hg	Tl	Pb	Bi	Po	At	Rn	
Fr	Ra	Ac	Rf	Ha	106	107	108	109	110	111	112							
			Ce	Pr	Nd	Pm	Sm	Eu	Gd	Tb	Dy	Ho	Er	Tm	Yb	Lu		
			Th	Pa	U	Np	Pu	Am	Cm	Bk	Cf	Es	Fm	Md	No	Lr		

- Materials with extreme properties:
 - High- T_c , Colossal MR, Metal-Insulator
 - Heavy Fermions, Quantum PT
 - Unconventional SC

Molecular Solids & Nanoclusters

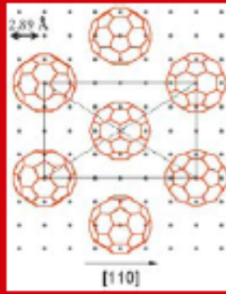

- C60,
- Nanotubes
- Monolayers of nanoclusters
- Organic Solids

ARPES

Physics in Low Dimensions

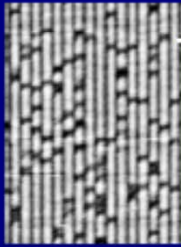

- 1D Wires
- Spin-Charge Separation
- 2D Surface States
- Quantum well states

Interfaces & Surfaces

- Correlated Heterostructures
- Unusual Surface Properties
- Liquid Overlayers



Beamline 5-4, SSRL (Stanford Synchrotron Radiation Laboratory)

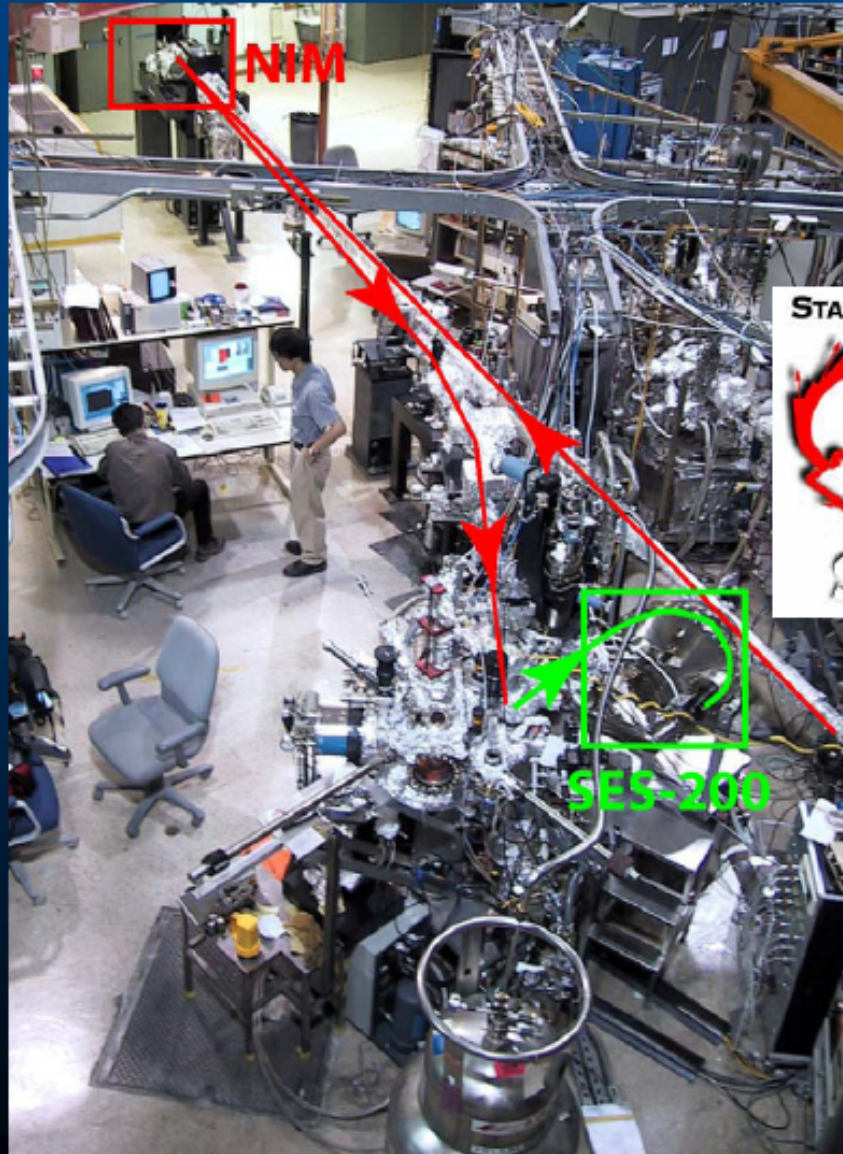



ALS / UC Berkeley: Beamline 10.0.1

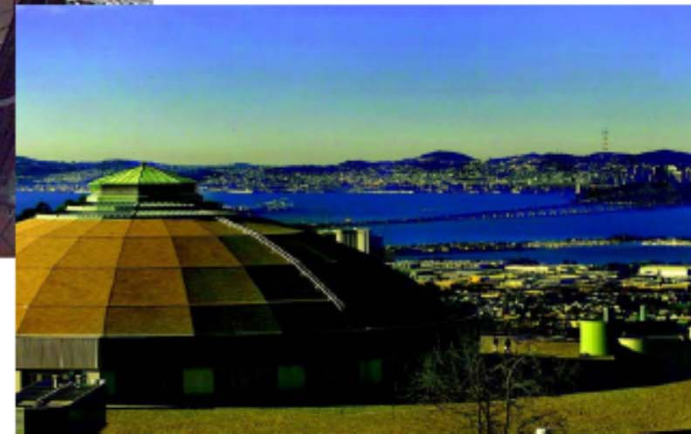
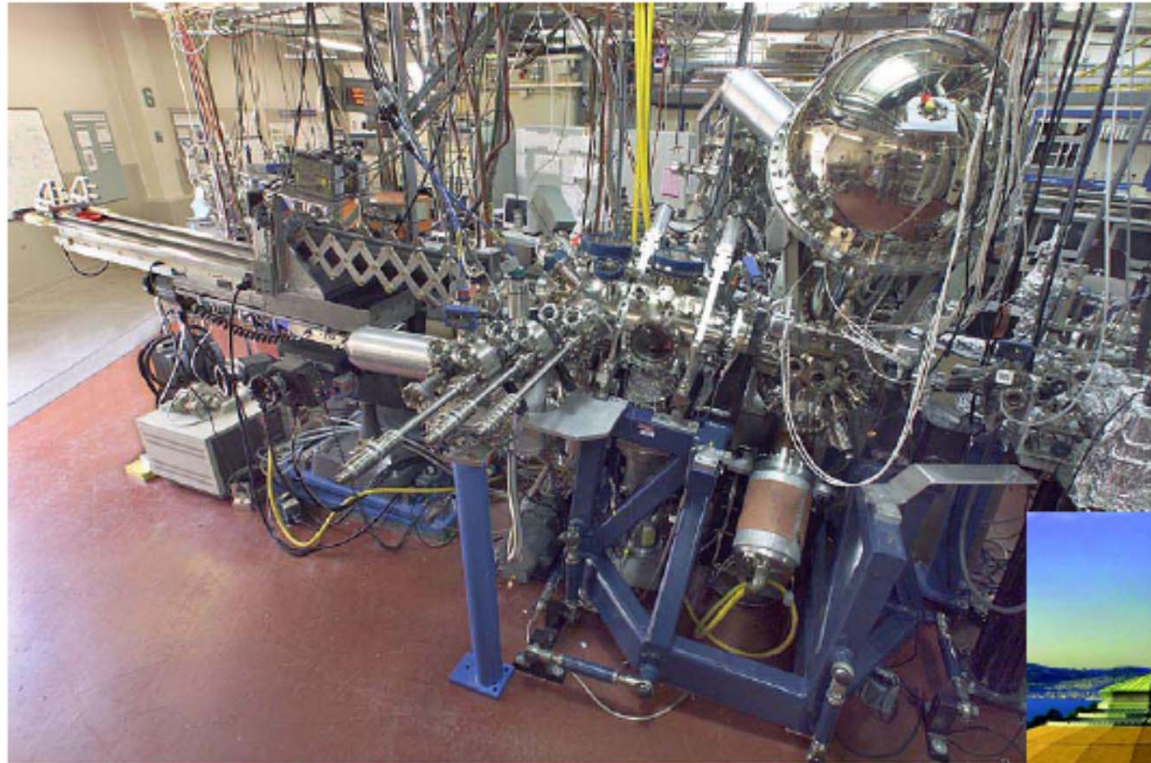



Geballe Laboratory for Advanced materials Stanford University (on-campus)

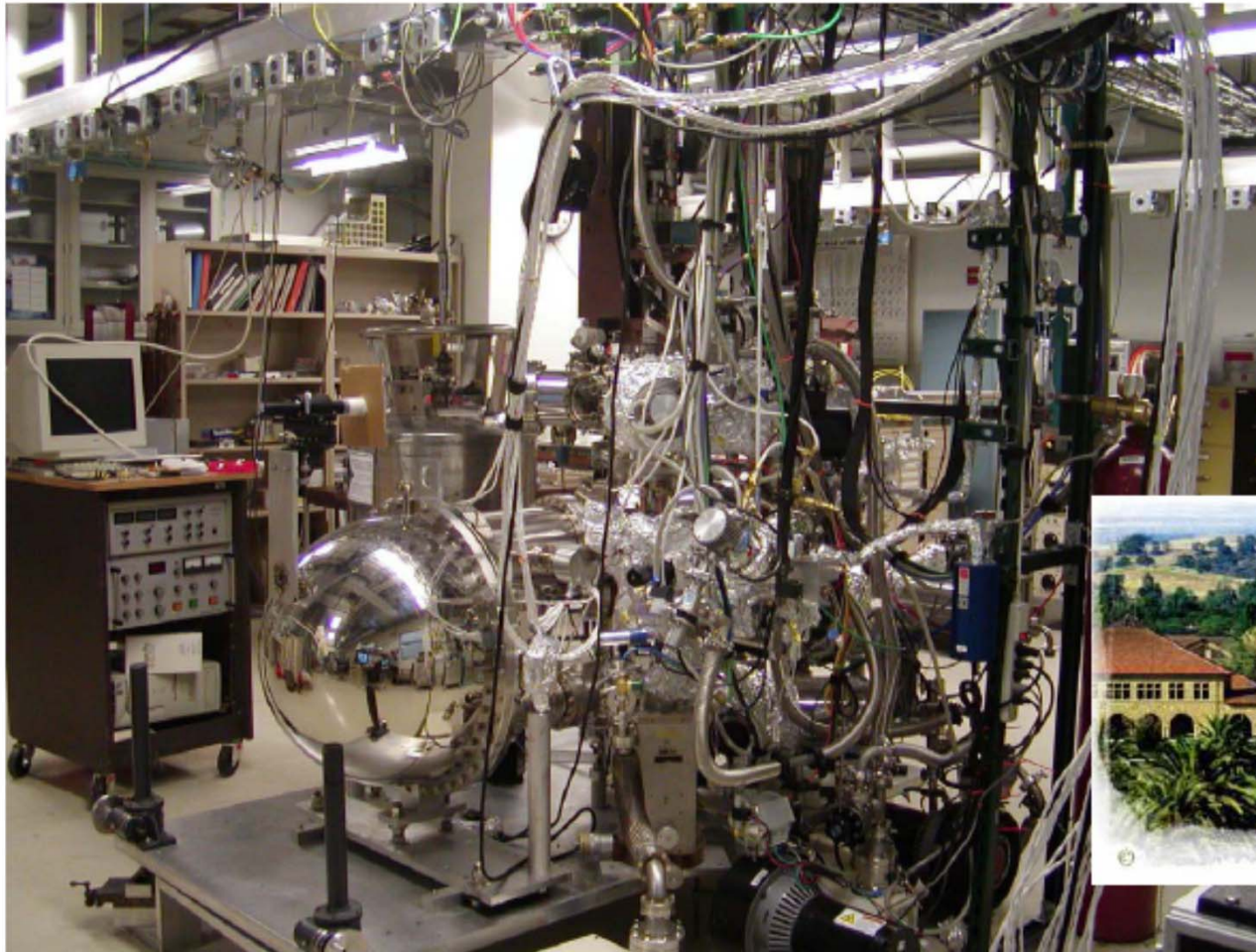

ARPES: Advantages and Limitations

Advantages

- **Direct information about the electronic states!**
- Straightforward comparison with theory - little or no modeling.
- High-resolution information about **BOTH energy and momentum**
- **Surface-sensitive probe**
- Sensitive to “**many-body**” effects
- Can be applied to small samples (100 μm x 100 μm x 10 nm)

Limitations

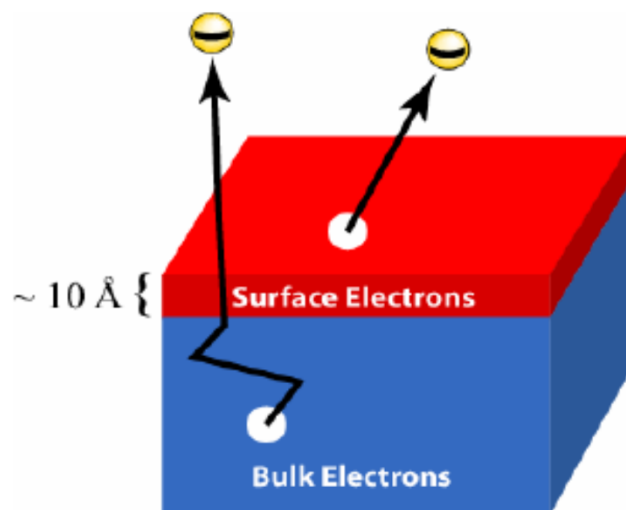

- **Not bulk sensitive**
- Requires clean, atomically flat surfaces in **ultra-high vacuum**
- Cannot be studied as a function of pressure or magnetic field

Future of Instrumentation

Instrumentation

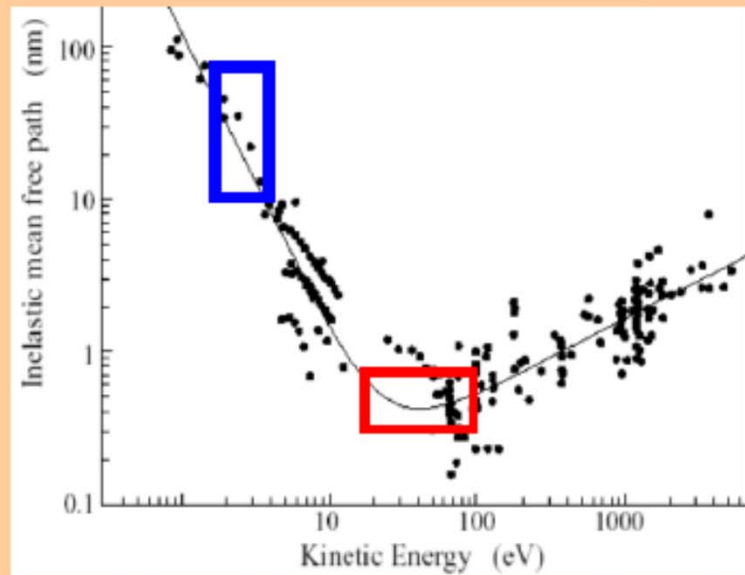

- Laser-based ARPES
- New Synchrotron Sources
- Spin-Resolved ARPES
- Complementary Spectroscopies

Laser-based ARPES

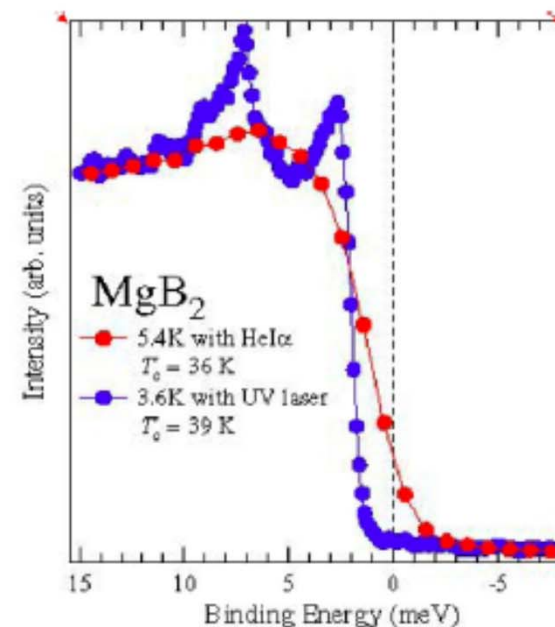

1. Enhanced Bulk Sensitivity
2. Higher Photon Flux
3. Higher Energy and k-Resolution
4. Small Spot Size ($\sim 1 \mu\text{m}$)
5. Polarization Control

S. Shin, University of Tokyo